

# Optimisation of Cogeneration Energy System in an Industrial Park using Cooperative Game Theory

Zhi Xin Tay, Jeng Shiun Lim\*, Sharifah Rafidah Wan Alwi, Zainuddin Abdul Manan

Process Systems Engineering Centre (PROSPECT), Research Institute for Sustainable Environment, School of Chemical and Energy Engineering, Faculty of Engineering, Universiti Teknologi Malaysia, 81310 UTM Johor Bahru, Johor, Malaysia  
[jslim@utm.my](mailto:jslim@utm.my)

Cogeneration or combined heat and power (CHP) is a proven energy-efficient technology for its ability to generate electricity and heat energies concurrently. In an industrial park, implementing the cogeneration energy system by different facilities requires a symbiosis synergy to determine the optimal design. Previous works have studied the cooperative coalition among tenants in an eco-industrial park. In this paper, the cooperative game theory explores the potential coalition between different facilities for optimal cogeneration implementation. The integrated optimisation framework is proposed to (1) minimise the overall cost and environmental emission constraints and (2) rationally allocate the investment costs and profits among the collaborating parties. The optimisation problem is solved as a mixed-integer linear programming (MILP) model by using GAMS software. The obtained optimal coalition has a TAC of RM 7.85 x 10<sup>6</sup>/y and assigns the iron-fabricating facility with a heat-to-power ratio of 2 as the anchor entity. The developed framework is crucial to laying the groundwork for macro-level cogeneration and peer-to-peer electricity trading planning in Malaysia.

## 1. Introduction

The accelerating climate change has highlighted the importance of achieving the sustainable balance of the energy trilemma, which would cover the aspects of energy security, environmental sustainability, and energy equity when designing future energy systems (World Energy Council, 2021). In 2019, COVID-19 caused an outbreak. The impacts are multi-dimensional as the global supply chain was disrupted and the energy market faltered – creating a unique opportunity for energy transition due to the increased risk of fossil fuel investment (Tian et al., 2022). While complete overhauling the carbonaceous energy system is possible, it is optimal and less expensive to transition from coal to gas before eventually installing carbon-free power. The intermediary plan could mildly unravel the intricate, vested economic and political interest of resource-abundant countries to adopt renewables in the future (Ahmadov and van der Borg, 2019). To facilitate the transition, cogeneration or combined heat and power (CHP) is deemed to be one practical energy-generating technology to be included in the future-proof energy system. CHP could generate electricity and heat concurrently, which leads to higher overall efficiency of 80 to 90 % compared to the conventional stand-alone generation of 35 to 55 % (Bilgen et al., 2015). As CHP produces energy on-site, it could increase the system's reliability, avoid transmission loss, reduce energy costs, and minimise greenhouse gases (GHG) emissions.

CHP is a multi-energy system (MES) because it requires coupled planning of electrical and gas systems that were previously dispatched independently. Tay et al. (2021) have attempted energy hub (EH) modelling to optimise a CHP energy system's operational strategy and unit selection with predetermined constraints. However, in an industrial park where facilities are arranged collectively in close geographic proximity, industrial symbiosis (IS) needs to be prioritised by encouraging mutually beneficial transactions of resources among different plants to achieve more significant overall betterment. The bottleneck of maximal potential for energy conservation within the independent company could be addressed through facilitated energy exchange only if the self-interest of each participating facility is fulfilled. Hence, the concept of game theory is selected as the framework to study the cooperative game structure of the multiple CHP facilities in an industrial park.

Among the methodologies to plan industrial parks via a game theory framework, Maali (2009) pioneered the representative multi-objective model to solve cooperative games via linear programming (LP). The model has

been utilised and applied to many studies in industrial park planning. Andiappan et al. (2015) have modelled the cooperative game in a palm oil eco-industrial park by synergising the operations of a palm oil mill, palm-based biorefinery, and biomass-based trigeneration system. Another paper by Wu et al. (2017) targeted an apartment, office, and hospital. Tan et al. (2020) extended the concept by pinpointing anchor internal processes thru inspection of the allocation of incremental economic benefits during cooperative game optimisation. Similarly, Chin et al. (2021) proposed a modified multi-stage game-theoretical design for water symbiosis.

Previous works have considered cooperative game design to allocate profits or costs rationally between the collaborating participants while identifying the anchor entity simultaneously. In those cases, CHP installations are optimised as one centralised unit to complement energy production for the industrial park as a whole. No study has analysed the possibility of separate cogeneration implementations for multiple facilities. Optimal energy dispatch for energy loads with different heat-to-power ratios is left unexplored. As such, this work proposes a cooperative game-based cost savings allocation framework for multiple cogeneration facilities by using multi-objective optimisation on EH modelling. The developed framework would adopt a mixed-integer linear programming (MILP) model to systematically optimise the energy unit selections, operational strategy, and cost savings allotment for the coalitional structure considering budget and environmental constraints. The research outcome would provide stakeholders with insights into potential large-scale cogeneration implementation planning by evaluating the achievable synergistic benefit.

## 2. Methodology

The development of the cooperative game-based optimisation model to rationally allocate the cost savings realised in a multi-EH network is presented in this section. The anchor facility would be identified as well.

### 2.1 Problem statement

The proposed cooperative game framework for optimising multi-EH coalition would need to be divided into two stages. Respectively, the cogeneration facility is modelled as an EH, which selects transformer(s), CHP(s), and auxiliary boiler(s) to convert the imported grid electricity and natural gas into useful energies to satisfy the site's electrical and thermal energy loads. Every EH could also transact excess generated electricity with one another via the existing connection to the grid. In Stage 1, multi-objective optimisation is carried out for all possible coalitional structures amongst the cogeneration facilities. Subsequently, in Stage 2, the total system cost savings in all partnerships are inputted into the cooperative game model to conduct the optimal allocation scheme and determine the anchor entity.

### 2.2 Multiple Cogeneration Energy Hubs Optimisation Model

The Optimal Cogeneration Model (OCM) proposed by Tay et al. (2021) is adapted and extended to include the interactions amongst the multiple EHs. Import and export of excess electricity are facilitated by the existing grid infrastructure. For an EH, there are designated electrical and heating loads,  $D_{eh,t}$  and  $D_{h,eh,t}$ , to be fulfilled by the energy transformation from the grid electricity and natural gas,  $E_{g,eh,t}$  and  $NG_{eh,t}$ . Transformer(s), CHP(s), and auxiliary boiler(s) could be selected to provide the energy outputs,  $Ep1_{eh,t}$ ,  $Ep2_{eh,t}$ ,  $Hp1_{eh,t}$ , and  $Hp2_{eh,t}$ , after considering the economic (investment and operating & maintenance (O&M) cost) and technical (efficiency and capacity limit) constraints. Flexibility is introduced to the dispatch strategy of EH by allowing charging ( $Ech_{eh,t-1}$  and  $Hch_{eh,t-1}$ ) and discharging ( $Edch_{eh,t}$  and  $Hdch_{eh,t}$ ) of energies utilising battery and thermal energy storage system (ESS). Additionally, excess generated electricity could be exported or imported,  $Eexp_{eh,t}$  and  $Eimp_{eh,t}$ , to and from the grid at a discounted rate. The superstructure of the problem is defined as follows (see Figure 1). The objective function of the multi-EH cogeneration optimisation model is to minimise the total annualised cost (TAC) of the cogeneration-integrated energy system with respect to the environmental constraint.

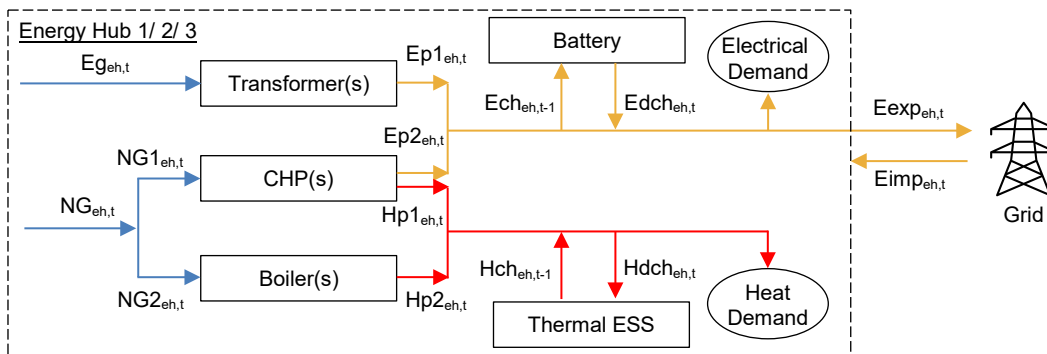

Figure 1: Superstructure of optimal multi-EH CHP design with the ability to transact grid electricity.

Eq(1)-(6) describe the formulation of TAC. The TAC considers four main cost components, namely total investment cost (TIC), total O&M cost (TOM), total utility cost (TUC), and total carbon emission cost (TCC), which quantifies the cost penalty for environmental constraints. The capital recovery factor (CRF) annualises the TIC based on the interest rate and project lifespan, while the annual operating day (AOD) scales up the TOM, TUC, and TCC. The sets of unit components and ESS are denoted as  $p$  and/ or  $es$ . The dispatch of energies is optimised to fulfil the energy loads of all EH at every time interval, which are represented as  $eh$  and  $t$ . In TIC and TOM,  $IC_{eh,p/es}$  is the fixed investment cost, while  $OMC_{eh,p}$  indicates the O&M costs for  $p$  and  $es$  at every  $eh$ . The integer decision for the number of  $p$  installations at  $eh$  is given as  $n_{eh,p}$ .  $Pgen^{e/h}_{eh,p,t}$  stands for the generated electricity and heat of  $p$  at a given  $t$  for  $eh$ . As for TUC, the grid-associated cost is accounted for by the summation of grid tariff, maximum demand charge, standby rate, and interpark tariff; the respective representations are  $Gtariff$ ,  $MDtariff$ ,  $SBtariff$ , and  $IPtariff$ .  $Eg_{eh,t}$ ,  $MD_{eh}$ ,  $SB_{eh}$ ,  $Eimp_{eh,t}$ , and  $Eexp_{eh,t}$  depict the grid purchase, maximum demand, standby capacity, imported and exported electricity. Natural gas procurement cost is described by the product of natural gas tariff and purchase capacity,  $NGtariff$  and  $NG_{eh,t}$ . GCPF and NGCPF translate to the carbon price factor for both electrical grid and natural gas facility in the TCC calculation.

$$\min TAC \quad (1)$$

$$TAC = CRF \times TIC + AOD \times (TOM + TUC + TCC) \quad (2)$$

$$TIC = \sum_{eh} \left( \sum_p IC_{eh,p} \times n_{eh,p} + \sum_{es} IC_{eh,es} \right) \quad (3)$$

$$TOM = \sum_{eh} \sum_p \sum_t (OMC_{eh,p} \times Pgen^{e/h}_{eh,p,t}) \quad (4)$$

$$TUC = \sum_{eh} \left( \left( \sum_t Gtariff \times Eg_{eh,t} + MDtariff \times MD_{eh} + SBtariff \times SB_{eh} \right) + \left( \sum_t NGtariff \times NG_{eh,t} \right) + \left( \sum_t IPTariff \times (Eimp_{eh,t} - Eexp_{eh,t}) \right) \right) \quad (5)$$

$$TCC = \sum_{eh} \left( \sum_t GCPF \times Eg_{eh,t} + \sum_t NGCPF \times NG_{eh,t} \right) \quad (6)$$

The following Eq(7) and (8) show the energy balance for the EH by the fulfilment of electrical and thermal energy loads,  $De_{eh,t}$  and  $Dh_{eh,t}$ , via the transformed energies from the transformer(s), CHP(s), and auxiliary boiler(s),  $Ep1_{eh,t}$ ,  $Ep2_{eh,t}$ ,  $Hp1_{eh,t}$ , and  $Hp2_{eh,t}$ . Charging and discharging of electrical and heat energies ( $Ech_{eh,t-1}$ ,  $Hch_{eh,t-1}$ ,  $Edch_{eh,t}$ , and  $Hdch_{eh,t}$ ) are enabled for ESS operation. Excess generated electricity,  $Eimp_{eh,t}$  and  $Eexp_{eh,t}$ , could be transacted amongst the facilities in the industrial park as well. The selection of EH units,  $p$  for  $eh$ , is depicted in Eq(9) and (10) where conversion efficiency ( $eff_p$ ), integer selection ( $n_{eh,p}$ ), and unit capacity ( $Cap_p^{max}$  and  $Cap_p^{min}$ ) are correlated.  $SOC^{e/h}_{es,t}$  represents the stored energy in the electrical (battery) and thermal ESS at a time interval,  $t$ . Eq(11) and (12) represent the dispatch of electricity and heat via EES by  $Ech^{e/h}_{eh,t}$ ,  $Hch^{e/h}_{eh,t}$ ,  $Edch^{e/h}_{eh,t}$ , and  $Hdch^{e/h}_{eh,t}$ .  $ceff^{e/h}$  and  $dceff^{e/h}$  are the charging and discharging, while  $IEch_{eh,t}$ ,  $IHch_{eh,t}$ ,  $IEDch_{eh,t}$ , and  $IHDch_{eh,t}$  are the binary dispatch decision. Similarly, eq(13) and (14) describe the interpark electricity transaction with binary  $IEimp_{eh,t}$  and  $IEexp_{eh,t}$ , while  $IPeff$  is the incurred loss during transmission.

$$De_{eh,t} + Ech_{eh,t} + Eexp_{eh,t} = Ep1_{eh,t} + Ep2_{eh,t} + Edch_{eh,t} + Eimp_{eh,t} \quad \forall eh \forall t \quad (7)$$

$$Dh_{eh,t} + Hch_{eh,t} = Hp1_{eh,t} + Hp2_{eh,t} + Hdch_{eh,t} \quad \forall eh \forall t \quad (8)$$

$$Pgen^{e/h}_{eh,p,t} = eff_p \times Eg_{eh,t} \text{ or } NG_{eh,t} \quad \forall eh \forall t \forall p \quad (9)$$

$$n_{eh,p} \times Cap_p^{min} \leq Pgen^{e/h}_{eh,p,t} \leq n_{eh,p} \times Cap_p^{max} \quad \forall eh \forall t \forall p \quad (10)$$

$$SOC_{eh,t+1}^{e/h} = SOC_{eh,t}^{e/h} + \frac{Ech_t^{e/h} \text{ or } Hch_t^{e/h}}{ceff^{e/h}} - \frac{Edch_t^{e/h} \text{ or } Hdch_t^{e/h}}{dceff^{e/h}} \quad \forall eh \quad \forall t \quad (11)$$

$$IEch_{eh,t} + IEedch_{eh,t} \text{ or } IHch_{eh,t} + IHdch_{eh,t} \leq 1 \quad \forall eh \quad \forall t \quad (12)$$

$$Eexp_{eh,t} \times Ipeff = Eimp_{eh,t} \quad \forall eh \quad \forall t \quad (13)$$

$$IEexp_{eh,t} + IEimp_{eh,t} \leq 1 \quad \forall eh \quad \forall t \quad (14)$$

### 2.3 Cooperative Game-based Cost Savings Allocation Model

Maali (2009) presented the cooperative game model that laid the groundwork for this work by modelling fair cost allocation amongst multiple facilities in an industrial park. Eq(15)-(19) show the formulation of the optimal cost savings allocation model with the objective function of maximising variable  $\lambda$ . The set of possible cooperative partnership is given by  $C$ , in which the facilities located within the industrial park is given by  $f$ . The basis weightage of a facility  $f$ ,  $W_f$ , is calculated based on the contribution portion in the coalitional structure.  $TS_c$  represents the total cost savings of the coalition, while  $TS_{wof}$  and  $TS_{wf}$  show the cost savings without and with facility  $f$ . The optimal cost savings allocation for facility  $f$  is  $CSAll_f$ , and it must be equal to or larger than the cost savings with facility  $f$  solely,  $TS_f$ . The sum of  $CSAll_f$  would then be equated to the  $TS_{wf}$  for optimisation.

$$\max \lambda \quad (15)$$

$$W_f = \frac{\sum_c (TS_c - TS_{wof})}{TS_{wf}} \quad \forall f \quad (16)$$

$$\frac{1}{W_f} CSAll_f \geq \lambda \quad \forall f \quad (17)$$

$$CSAll_f \geq TS_f \quad \forall f \quad (18)$$

$$\sum_f CSAll_f = TS_{wf} \quad \forall f \quad (19)$$

### 3. Case study

It is assumed that the industrial park is in Malaysia, and three facilities are considering the coalitional feasibility of integrating CHP and peer-to-peer electricity trading. The load profile of typical (EH1) iron-fabricating, (EH2) plastic-manufacturing, and (EH3) general manufacturing are normalised and adapted from the dataset by Angizeh et al. (2020). By adopting a heat-to-power ratio of 2, 1.5, and 1, the thermal loads are postulated. The `RANDBETWEEN` formula in Excel accounts for the  $\pm 5\%$  fluctuations in the actual value. Figure 2 shows the EHs' load profiles modelled after the three facilities. The applicable tariffs for the grid electricity and natural gas are provisioned by the Tenaga Nasional Berhad (TNB) (Tenaga Nasional Berhad, 2014) and Gas Malaysia Energy & Services Sdn. Bhd. (GMES) (Energy Commission, 2022). As for the interpark tariff, the in-place marginal price system is overseen by the ring-fenced Single Buyer department within TNB (Single Buyer, 2022). The values of GCPF and NGCPF are adapted from Tay et al. (2021). Table 1 lists all the mentioned tariffs.

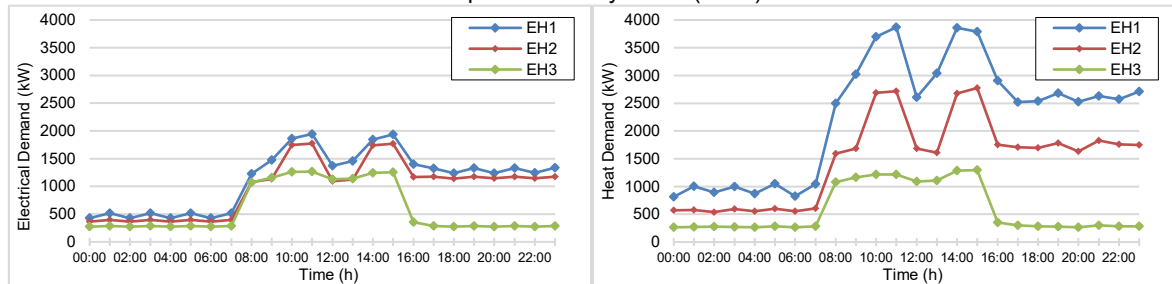

Figure 2: Energy load profiles of (EH1) iron-fabricating, (EH2) plastic-manufacturing, and (EH3) general manufacturing facilities with heat-to-power ratio of 2, 1.5, and 1.

Table 1: The associated costs for the connections of energy hubs to the electrical grid and gas infrastructure

	Electrical Grid		Gas Infrastructure		Interpark Connection			Carbon Price Factor			
On-Peak	0.355	RM/kWh	Average	0.124	RM/kWh	On-Peak	0.247	RM/kWh	Electrical	0.972	RM/kWh
Off-Peak	0.219	RM/kWh				Off-Peak	0.213	RM/kWh	Grid		
Maximum Demand	37.00	RM/kW							Natural Gas	0.230	RM/kWh
Standby	14.00	RM/kW									

### 3.1 Results and discussion

The multi-period optimisation of the TAC for an industrial park considers an AOD of 365 d with 24 h a day by selecting the operating technologies as reported in Tay et al. (2021). The evaluation lifetime is 10 y with a 6 % discount rate, giving a CRF of 0.136. In this case study, the three facilities in the industrial park are considering the feasibility of CHP implementation with enabled interpark electricity trading. To obtain the optimal cost savings allocation model, repeated optimisations are conducted by considering (1) facilities without CHP implementation and (2) integration of CHP and interpark connection for all possible coalition. Table 2 shows the postulation result of the cost savings in the cooperative game. The coalition,  $C_7$ , formed from EH1, EH2, and EH3 has a  $TS_{1,2,3}$  of RM 7,845,284.66/y, which is greater than all other arrangements. As shown in Table 3, the cost savings allocation (CSAll) for each facility is objectively higher than their initial total cost savings (TS) before forming a coalition.  $C_1$ , which includes  $f_1$  or EH1 solely, is selected as the anchor entity with the highest percentage allocation of 41.47 % - which coincides with it having the largest heat-to-power ratio of 2 amongst all facilities.

Table 2: The coalitional cost savings and optimal allocation scheme for each facility in an industrial park

Coalition	Facility	Total Annual Cost, TAC without CHP (RM $10^6$ /y)	Total Annual Cost, TAC with coalition (RM $10^6$ /y)	Total Cost Savings, TS (RM $10^6$ /y)
$C_1$	$f_1$	12.10	8.90	3.21
$C_2$	$f_2$	9.25	6.46	2.78
$C_3$	$f_3$	4.81	3.14	1.67
$C_4$	$f_1, f_2$	21.35	15.30	6.05
$C_5$	$f_1, f_3$	16.92	11.94	4.97
$C_6$	$f_2, f_3$	14.06	9.49	4.57
$C_7$	$f_1, f_2, f_3$	26.16	18.32	7.85

Figure 3 illustrates the optimal operational strategy of the coalition. It is observed that (1) transformer(s) are entirely replaced by CHP(s) as  $Ep_{1,eh,t}$  is non-existent, (2) EH3 does not need to install CHP themselves as the excess electricity can be procured as  $Eimp$ , (3) export of electricity is preferred over charging of battery as shown in EH1 and EH2 due to it being much more cost-effective. As CHP(s) are installed in EH1 and EH2 only, the heat demand of EH3 is entirely fulfilled completely by the boiler(s).

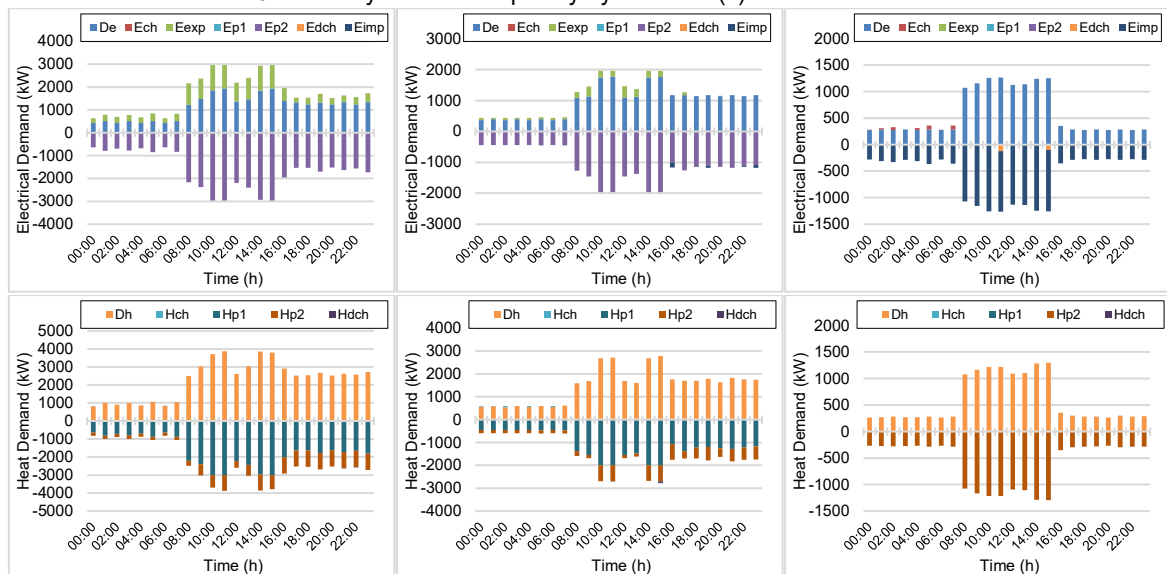

Figure 3: Energy dispatch profile for (EH1) iron-fabricating, (EH2) plastic-manufacturing, and (EH3) general manufacturing facilities in optimal coalition  $C_7$

To verify the effect of the heat-to-power ratio on determining cost savings allocation, sensitivity analysis is conducted by altering the heat-to-power ratio for the facilities in the research, as in Table 3. Case (A) shows that the anchor process is dependent on the entity with the largest heat-to-power ratio, while case (B) indicates that bigger differences in heat-to-power ratio can contribute to more significant potential cost savings.

Table 3: Sensitivity analysis to consider different heat-to-power ratios

Scenario	Heat-to-Power Ratio			Total Cost Savings (RM 10 <sup>6</sup> /y)	Allocation (RM 10 <sup>6</sup> /y)			Percentage (%)		
	EH1	EH2	EH3		EH1	EH2	EH3	EH1	EH2	EH3
Base Case	2	1.5	1	7.85	3.25	2.84	1.75	41.47	36.20	22.33
A	1.5	2	1	8.34	3.19	3.47	1.67	38.31	41.61	20.07
B	2.5	1.5	1	7.87	3.28	2.84	1.75	41.65	36.08	22.26

#### 4. Conclusions

This work proposed a cooperative game model for optimal cost savings allocations amongst facilities in an industrial park. The possible coalitions are optimised separately to obtain the initial value of cost savings, then input into the developed framework to determine the anchor entity. The optimal coalition incurs a TAC of RM 7.85 x 10<sup>6</sup>/y and identifies EH1 with a heat-to-power ratio of 2 as the anchor entity (allocates RM 3.25 x 10<sup>6</sup>/y or 41.47 %). This analysis shows that symbiotic cogeneration implementation in an industrial park has untapped potential. While this paper considers only three facilities, the framework could be applied to a larger industrial park by categorising the premises according to their heat-to-power ratios to reduce computational difficulties. In future work, the proposed framework could be extended to include more dimensions in the optimisation process, such as social parameters, to provide a better insight into the inner workings of an industrial park.

#### Acknowledgments

The authors would like to thank Universiti Teknologi Malaysia (UTM) for providing the research fund for this study (grant number: Q.J130000.2451.08G48).

#### References

- Ahmadov A.K., van der Borg C., 2019, Do natural resources impede renewable energy production in the EU? A mixed-methods analysis, *Energy policy*, 126, 361-369.
- Andiappan V., Tan R.R., Ng D.K.S., 2015, Systematic allocation of cost savings among energy systems in an eco-industrial park, *Chemical Engineering Transactions*, 45, 1657-1662.
- Angizeh F., Ghofrani A., Jafari M.A., 2020, Dataset on Hourly Load Profiles for a Set of 24 Facilities from Industrial, Commercial, and Residential End-use Sectors, Mendeley Data. DOI: 10.17632/rfnp2d3kjp.1
- Bilgen S., Keleş S., Sarıkaya İ., Kaygusuz K., 2015, A perspective for potential and technology of bioenergy in Turkey: Present case and future view, *Renewable and Sustainable Energy Reviews*, 48, 228-239.
- Chin H.H., Varbanov P.S., Klemeš J.J., Bandyopadhyay S., 2021, Subsidised water symbiosis of eco-industrial parks: A multi-stage game theory approach, *Computers & Chemical Engineering*, 155, 107539.
- Maali Y., 2009, A multiobjective approach for solving cooperative n-person games, *International Journal of Electrical Power & Energy Systems*, 31(10), 608-610.
- Malaysia Energy Commission, 2022, Gas Prices and Tariffs, <st.gov.my/en/web/consumer/details/2/10>, accessed 01.04.2022.
- Single Buyer, 2022, System Marginal Price: Daily Forecast and Actual SMP, <singlebuyer.com.my/resources-marginal.php>, accessed 01.04.2022.
- Tan Y.D., Lim J.S., Alwi S.R.W., Andiappan V., 2020, Targeting anchor process via cooperative game-based optimisation approach within integrated palm oil-based complex, *Chemical Engineering Transactions*, 81, 31-36.
- Tay Z.X., Lim J.S., Alwi S.R.W., Manan Z.A., 2021, Optimal Planning for the Cogeneration Energy System using Energy Hub Model, *Chemical Engineering Transactions*, 88, 349-354.
- Tenaga Nasional Berhad, 2014, Electricity Tariff Schedule, <tnb.com.my/assets/files/Tariff\_Rate\_Final\_01.Jan.2014.pdf>, accessed 01.04.2022.
- Tian J., Yu L., Xue R., Zhuang S., Shan Y., 2022, Global low-carbon energy transition in the post-COVID-19 era, *Applied Energy*, 307, 118205.
- World Energy Council, 2021, World Energy Trilemma Index 2021, <worldenergy.org/publications/entry/world-energy-trilemma-index-2021>, accessed 01.04.2022.
- Wu Q., Ren H., Gao W., Ren J., Lao C., 2017, Profit allocation analysis among the distributed energy network participants based on Game-theory, *Energy*, 118, 783-794.