

# Enhanced Biobutanol Separation by a Heat Pump Assisted Azeotropic Dividing-Wall Column

Iulian Patrascu<sup>a</sup>, Costin Sorin Bîldea<sup>a</sup>, Anton A. Kiss<sup>b,c,\*</sup>

<sup>a</sup>University "Politehnica" of Bucharest, Polizu 1-7, 011061 Bucharest, Romania

<sup>b</sup>The University of Manchester, School of Chemical Engineering and Analytical Science, Centre for Process Integration, Sackville Street, The Mill, Manchester M13 9PL, United Kingdom

<sup>c</sup>University of Twente, Sustainable Process Technology, PO Box 217, 7500 AE Enschede, The Netherlands  
[tony.kiss@manchester.ac.uk](mailto:tony.kiss@manchester.ac.uk)

Stronger sustainability needs for the production of fuels and chemicals have spurred extensive research to substitute fossil fuel sources by renewable sources. Yet, the major cost of biorefineries is in the downstream processing. This issue has to be addressed properly to make biofuels an economically viable alternative.

As a renewable fuel, biobutanol is produced from biomass feedstocks. But after the fermentation step it has a very low concentration (less than 3 %wt) that leads to high energy requirements for onventional downstream separation. To reduce the energy penalty, we describe here a new hybrid separation process based on a heat pump assisted azeotropic dividing-wall column (A-DWC). CAPE tools and Pinch analysis were used for the process synthesis, design and optimization of the process. The plant capacity considered here is 40 ktpy butanol (99.4 %wt). Remarkably, the energy requirement for butanol separation using heat integration and vapour recompression assisted A-DWC is reduced by 58% from 6.3 to 2.7 MJ/kg butanol.

## 1. Introduction

Due to its remarkable properties (e.g. low water miscibility, flammability and corrosiveness) biobutanol can replace gasoline in existing car engines. But its current production costs prohibit biobutanol use as a biofuel. In the fermentation process of acetone-butanol-ethanol (ABE), diluted biobutanol is obtained with a concentration of less than 3 %wt. The productivity, yield and concentration can be improved by genetic engineering, but this is a longer-term goal to be achieved. A higher butanol yield is achieved in fermentation using anaerobic bacteria as *Clostridium acetobutylicum* and *Clostridium beijerinckii* (Tashiro et al., 2013).

The low concentration of butanol obtained by fermentation leads to significant penalties in the energy required for downstream processing, typically in the range of 14.7-79.05 MJ/kg butanol (Patrascu et al., 2017). This has a major impact on the costs for separation, which have to be drastically reduced. Many separation techniques are available for the ABE separation, e.g. distillation, reverse osmosis, adsorption, liquid-liquid extraction and others (Abdehagh et al., 2014; Sanchez-Ramirez et al., 2017). Another way to increase the concentration of ABE in the outlet stream of fermentation is by in-situ product recovery (ISPR), e.g. by gas stripping (Lodi and Pellegrini, 2016) which can lead to ABE: 4.5 %wt acetone, 18.6 %wt butanol and 0.9 %wt ethanol (Xue et al., 2013). Using this stream as start of the downstream processing, distillation becomes more reasonable.

The conventional separation sequence using three distillation columns along with one decanter (Figure 1, left) requires 6.3 MJ/kg butanol. By using heat integration and combining two columns into a dividing-wall column (Figure 1, right), about 29 % reduction of the energy requirement was achieved (Patrascu et al, 2017). This is a significant reduction of the energy requirements, but can the energy savings be pushed any further? To achieve more savings, a novel process is proposed in this work. The azeotropic DWC combines three distillation columns into one unit and reduces the energy used for separation by employing a heat pump (vapor recompression) and heat integration. (Kiss, 2013; 2014). The decanter is not used here as the first separation unit, as the organic phase (rich in butanol) has a high impact on the reboiler duty for butanol purification and makes heat pumping very inefficient. By using a highly integrated azeotropic dividing-wall column (A-DWC) assisted by vapor recompression (VRC) technology, significant energy savings are possible.

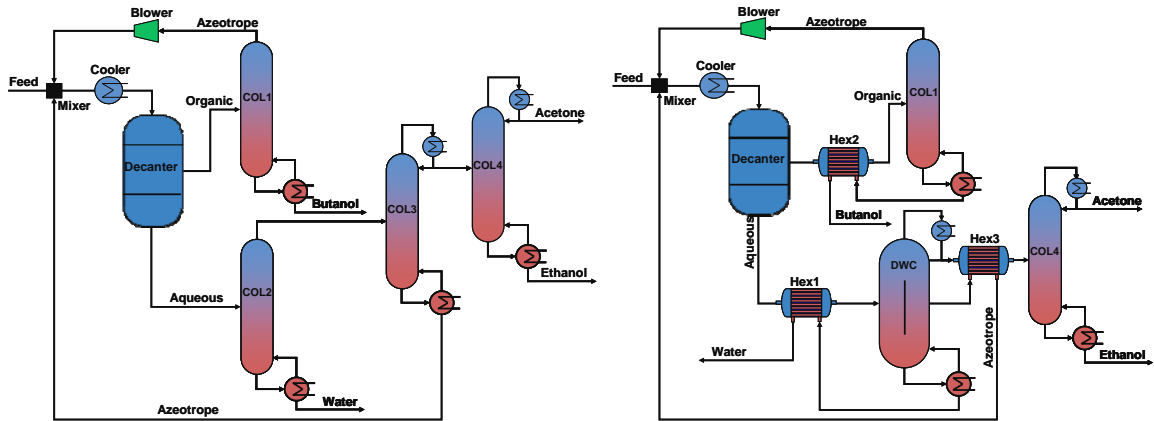

Figure 1. Process flowsheet of ABE downstream separation sequences (Patrascu et al., 2017)

## 2. Modeling approach

The downstream process was rigorously simulated in Aspen Plus, using the NRTL as suitable property model. As the fourth column (COL-4) shown in Figure 1 separates only the light components (acetone and ethanol, which could be also used directly as fuel), it is not included in the energy requirement for butanol separation. To account for a realistic composition of the ABE mixture, impurities are taken into account: 0.1 % wt.  $\text{CO}_2$ , as well as small amounts of acetic acid and butyric acid. Several basic assumptions and design specifications are used for the optimization and heat integration: butanol purity is 99.4 % wt.; each side of the dividing wall has the same number of stages; feed streams are preheated to 97 °C; product streams are cooled to 25 °C; the (left) side reboiler is not considered in optimization process of A-DWC because will be replaced with a heat exchanger. Pinch analysis was used to determine the energy targets and the design of the heat exchange network (HEN). The investment and operation costs of the novel process were evaluated to show the benefits of this design (Dimian et al., 2014). The coefficient of performance (COP) was used to evaluate the feasibility of heat pumping, while taking into account the additional costs for compression and the limited payback time.

## 3. Results and discussion

### 3.1 Process design and development

Figure 2 shows the transition process configurations used to arrive eventually to the new process based on an azeotropic dividing-wall column (A-DWC). Based on the overlap of operating conditions and composition match, the three distillation columns can be conveniently integrated into just a single A-DWC unit. Heat pump and energy integration is considered in the next design step. Figure 3 illustrates the flowsheet of the heat integrated process with a heat pump assisted A-DWC at heart. The mass and energy balance is also included.

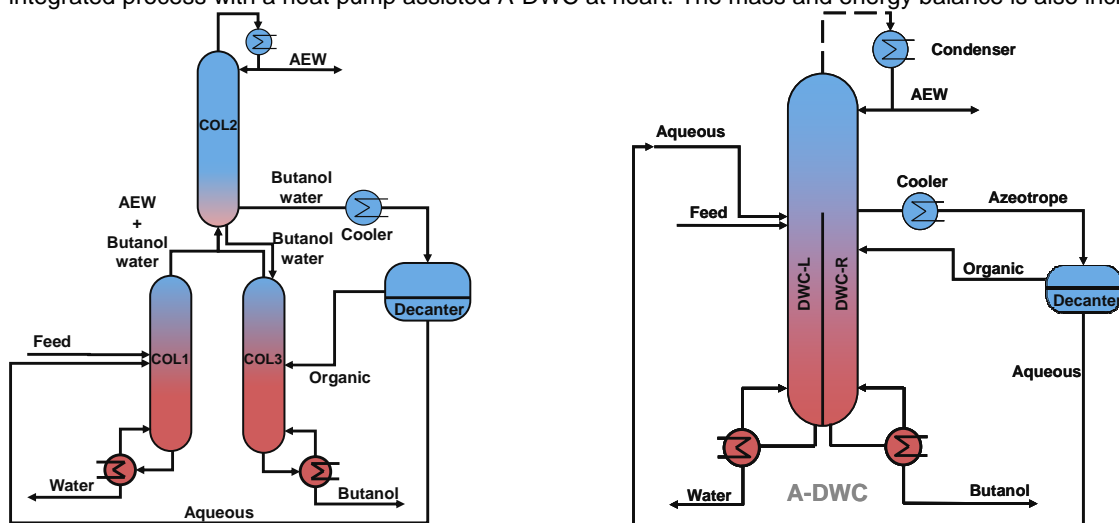

Figure 2. Alternative distillation-decanter configuration (left) and corresponding azeotropic DWC (right)

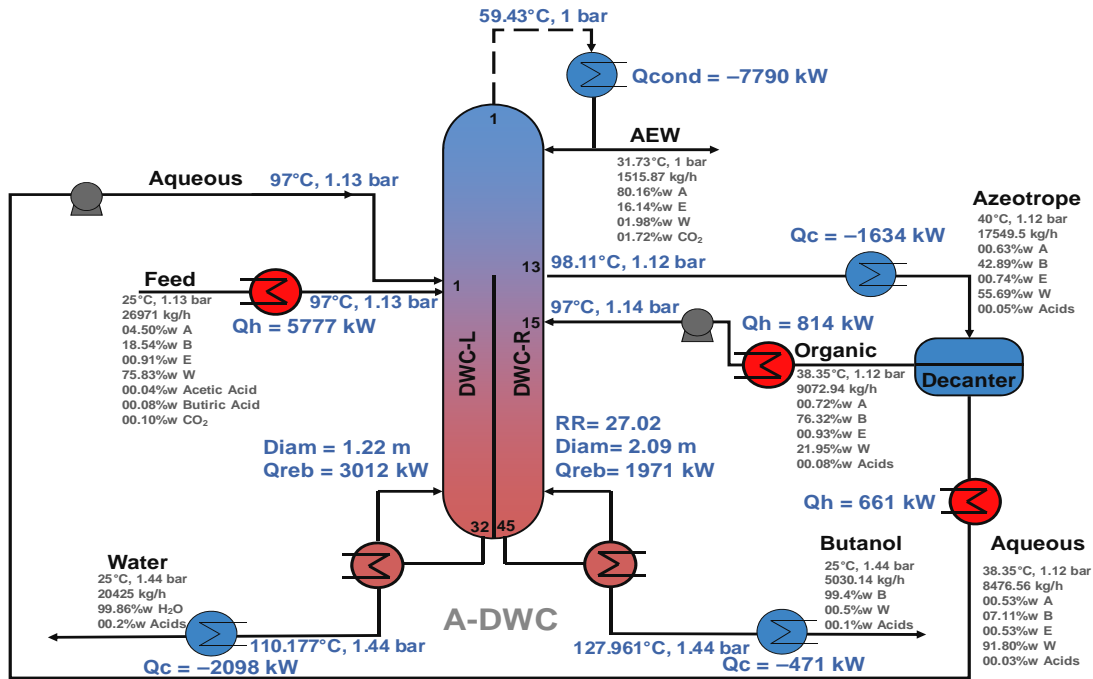

Figure 3. Flowsheet of the new process using azeotropic DWC, including mass and energy balance

Heat integration leads usually to significant reduction of heating and cooling requirements. Pinch analysis was used to determine the energy targets as well as the configuration of the optimal heat exchanger network. As shown in Figure 3, the vapor stream from the top of the A-DWC has low temperature hence it cannot be used for heat integration. However, by recompressing the vapor to 5.8 bar, the temperature increases to 150 °C, which is useful for heat integration. The maximum energy savings are given by (Blahusiak et al., 2018):

$$\text{Max. savings (\%)} = 100 \cdot \frac{Q_{reb} - HR \cdot Q_{reb} / COP}{Q_{reb}} \quad (1)$$

Figure 4 shows the dependence on pressure of the log-mean temperature difference (LMTD) and compressor power (Patrascu et al., 2018). The LMTD must exceed 5 K to obtain an acceptable heat exchange area and hence not an expensive heat exchanger (HEX). The compressor is limited by the compression ratio (up to 2.5-4.0) and also by the discharge temperature which should not exceed 150°C for safety reasons: at higher temperatures the system may fail from worn rings, acid formations, oil breakdown (Luo et al., 2015).

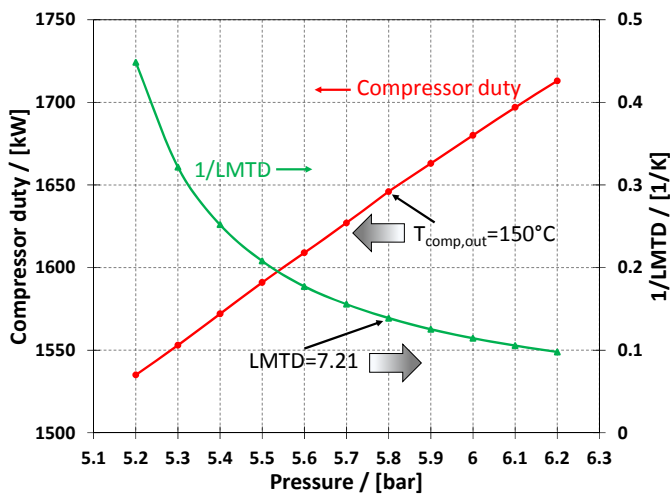

Figure 4. Dependence of compressor duty and the long-mean temperature difference (LMTD) on the pressure

### 3.2 Heat integrated heat pump assisted A-DWC process

The complete process flowsheet – including the main design parameters and the energy balance – is shown in Figure 5 (Patrascu et al., 2018). The A-DWC column has 45 stages in total, with 13 stages for the fractionation section and 32 stages for the stripping section. Butanol and water are the two bottom products, while a mixture of acetone and ethanol with some water (AEW) is removed as distillate. The ABE feed and the aqueous phase recycled from the decanter are fed on 1st stage of the stripping section (14th stage of A-DWC), which separates water as bottom product. The top vapor stream is compressed to 5.8 bar (150 °C), provides heat to the (left) side reboiler (HEX1), preheats the diluted ABE feed (HEX2) and is finally condensed. The liquid flowing down the column is routed to the right stripping section. From the 13th stage, a mixture close to the azeotropic composition is withdrawn as side stream, cooled, and sent to the decanter. The organic phase is recycled on 2nd stage of the right stripping section (15th stage of A-DWC), from which butanol is obtained as bottom product. Additional heat is recovered by using the water product stream to preheat the aqueous and organic phases (HEX3, HEX4).

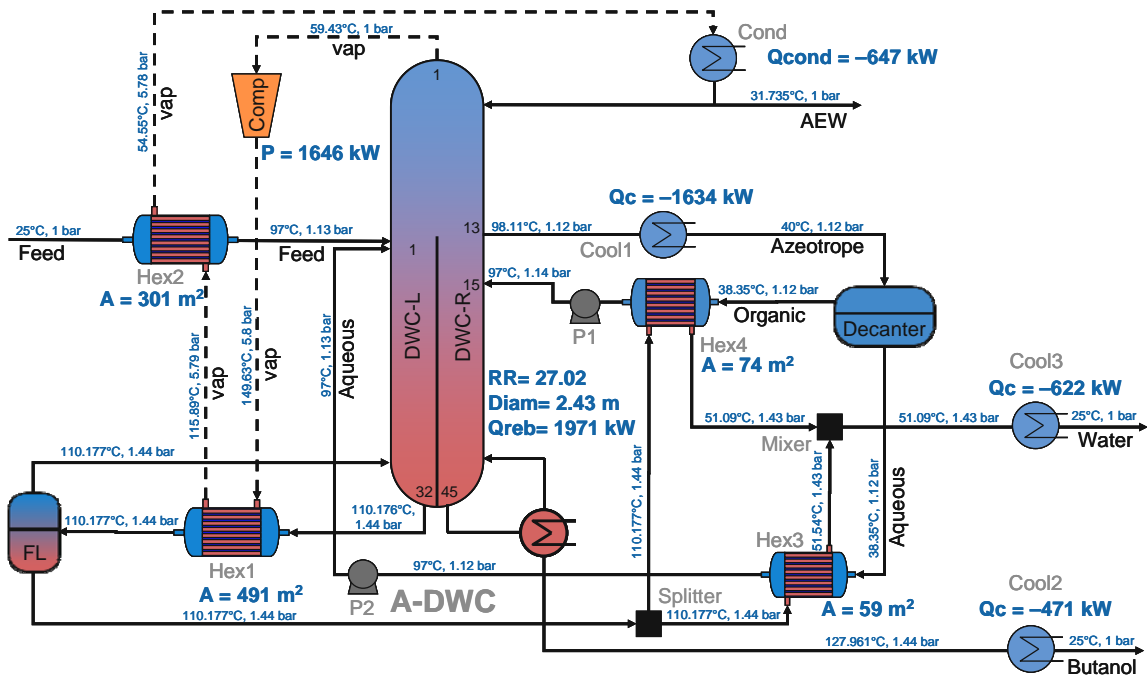

Figure 5. Process flowsheet of the new downstream separation heat-integrated process based on A-DWC

Figure 6 plots the temperature and the liquid composition profiles in the A-DWC unit. Note that the bottom of the column shows two temperatures due to the use of two reboilers, for the water and butanol products.

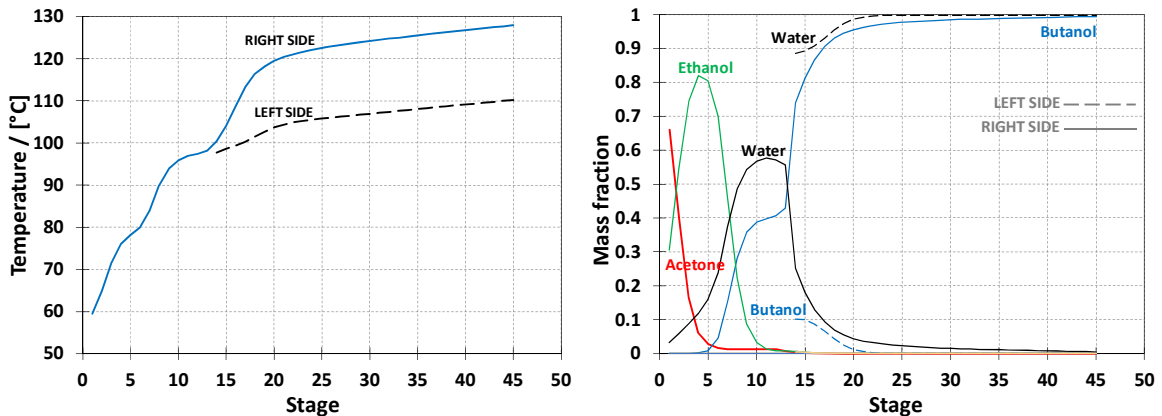

Figure 6. Temperature and liquid composition profiles along the A-DWC unit (Patrascu et al., 2018)

The temperature difference between the two sides of the dividing-wall does not exceed 20 K hence there is no need for special insulating measures. In terms of composition, the liquid composition profiles confirm the high purity of the bottom products, while a ternary mixture (AEW) is obtained as distillate stream. On the 13th stage it can be observed the composition of the heterogeneous azeotrope (butanol-water), while the aqueous and organic phase can be observed on the 14th stage for both sides of the dividing wall. Despite the high degree of integration, such processes combining vapor recompression with (extractive) DWC technology have been reported to be also controllable (Patrascu et al., 2017; Luyben, 2017).

#### 4. Process evaluation

The process is optimized using the total annual cost (TAC) as the objective function to be minimized.

$$TAC = OpEx + \frac{CapEx}{Payback\ period} \quad (2)$$

where a payback period of 3 years is considered, with 8000 hours/year operating time.

The main design parameters (e.g. number of trays, feed tray location) are used as decision variables in the optimization (Patrascu et al., 2017). The capital expenditures (CapEX) include the heat exchangers, coolers, heat pump, flash unit, distillation column, and the decanter. The heating and cooling costs considered are standard: LP steam (at 6 bar, 160 °C, \$7.78/GJ), cooling water (at 25 °C, \$0.72/GJ) and chilled water (at 5 °C, \$4.43/GJ). The compressor power cost taken into account is 15.5 \$ per GJ electrical power.

Table 1 provides details of the economic evaluation of the new process for butanol recovery, based on a heat-integrated heat pump assisted A-DWC (Patrascu et al., 2018). The total equipment cost is evaluated at 5250 k\$/year. The optimal operating cost is 1435 k\$/year, including also the cooling of the products.

Table 1. Economic evaluation of the heat pump assisted A-DWC for butanol recovery

Item description (unit)	DWC	Decanter	Coolers	Exchangers	Flash &Comp
Shell / [10 <sup>3</sup> US\$]	718.1	71.6	-	-	1618.9
Trays / [10 <sup>3</sup> US\$]	94.6	-	-	-	-
Condenser / [10 <sup>3</sup> US\$]	266.7	-	1179.5	-	-
Reboiler / [10 <sup>3</sup> US\$]	497.8	-	-	803.4	-
Heating / [10 <sup>3</sup> US\$/year]	441.8	-	-	-	737.3
Cooling / [10 <sup>3</sup> US\$/year]	82.5	-	173.2	-	-
TAC / [10 <sup>3</sup> US\$/year]	1050.0	23.9	566.4	267.8	1276.8

A quick comparison of the energy efficiency for various process alternatives reveals the following results:

- 6.30 MJ/kg butanol, for the optimized conventional decanter-distillation process (Patrascu et al., 2017)
- 4.46 MJ/kg butanol, for the dividing-wall column process (Patrascu et al., 2017)
- 8.78 MJ/kg butanol, for the azeotropic DWC process (without heat integration and vapor recompression)
- 7.78 MJ/kg butanol, for the azeotropic DWC process (with heat integration, but no vapor recompression)
- 2.70 MJ/kg butanol, for the heat-integrated heat pump assisted A-DWC process (this work)

Remarkable, the heat-integrated heat pump assisted A-DWC process requires only 2.7 MJ/kg butanol (58% less than in conventional separation sequence). This energy efficiency is better than liquid-liquid extraction or supercritical extraction processes (Salemme et al., 2016). However, using a heat pump increases the capital cost due to the expensive compressor (1581.5 k\$). Nonetheless, considering the energy savings (1.69 MJ/kg butanol) evaluated at 1893 k\$/year, the payback time is less than a year (about 10 months).

The potential environmental impact was evaluated in Aspen Plus using Carbon Tracking to calculate the CO<sub>2</sub> emissions. The fuel source considered is natural gas and the CO<sub>2</sub> emission factor data source used is the US Environmental Protection Agency Rule of 'E9-5711' (CO<sub>2</sub> E-US) proposed in 2009. The standard used for the Global Warming Potential is USEPA (2009) with a carbon tax of 5 \$/ton. The CO<sub>2</sub> emissions are estimated at 1429 kg/h (11.43 ktpy) for the complete downstream process (heat-integrated heat pump assisted A-DWC). The total net carbon tax has been evaluated at 7.87 \$/h (62.96 k\$/year). CO<sub>2</sub> emissions were calculated as:

$$[CO_2]_{emissions} = \left( \frac{Q_{fuel}}{NHV} \right) \left( \frac{C\%}{100} \right) \alpha \quad (3)$$

$$Q_{fuel} = \left( \frac{Q_{proc}}{\lambda_{proc}} \right) (h_{proc} - 419) \frac{(T_{FTB} - T_0)}{(T_{FTB} - T_{stack})} \quad (4)$$

where  $\alpha = 3.67$  is the ratio of molar masses of CO<sub>2</sub> and C; *NHV* (net heating value) is 48900 kJ/kg for natural gas; *C%* (carbon content) is 0.41 kg/kg;  $Q_{proc}$  is the heat duty required by the process and duty provided by the stripping steam (kW);  $\lambda_{proc}$  is the latent heat of steam delivered to the process (kJ/kg);  $h_{proc}$  is the enthalpy of steam delivered to the process (kJ/kg);  $T_0$  is the ambient temperature;  $T_{FTB}$  (K) and  $T_{stack}$  (K) are the flame and stack temperature, respectively.

## 5. Conclusions

The novel process proposed here was effectively designed, optimized, and heat integrated allowing the bio-butanol recovery (from the ABE mixture obtained by fermentation) in only few separation units: three classic distillation columns are combined into one azeotropic dividing-wall column (A-DWC) and one decanter is used for the liquid-liquid split of the heterogeneous azeotrope. The energy requirements (and the associated CO<sub>2</sub> emissions) are drastically reduced further by applying heat integration and vapor recompression. The economic evaluation proves that it is feasible, with the investment costs of the downstream process (40 ktpy capacity) of 5250 k\$, and the operating cost of 1434 k\$/year. Although, the cost of the compressor (required for VRC) is rather high (1581.5 k\$), the payback period is less than one year (10 months). The highly integrated process reduces by 58% the energy usage for butanol separation to only 2.7 MJ/kg butanol.

## Acknowledgments

The financial support of the European Commission through the European Regional Development Fund and of the Romanian state budget, under the grant agreement 155/25.11.2016 Project POC P-37-449 (ASPiRE) is appreciatively recognized. AAK thankfully acknowledges the Royal Society Wolfson Research Merit Award.

## References

- Abdehagh N., Tezel F. H., Thibault J., 2014, Separation techniques in butanol production: Challenges and developments, *Biomass and Bioenergy*, 60, 222-246.
- Blahusiak M., Kiss A. A., Babic K., Kersten S. R. A., Bargeman G., Schuur B., 2018, Insights into the selection and design of fluid separation processes, *Separation and Purification Technology*, 194, 301-318.
- Dimian A.C., Bildea C.S., Kiss A.A., 2014, *Integrated design and simulation of chemical processes*, 2nd Edition, Elsevier, Amsterdam.
- Kiss A.A., 2013, *Advanced distillation technologies - Design, control and applications*, Wiley, Chichester, UK.
- Kiss A.A., 2014, Distillation technology - Still young and full of breakthrough opportunities, *Journal of Chemical Technology and Biotechnology*, 89, 479-498.
- Lodi G., Pellegrini L.A., 2016, Recovery of butanol from ABE fermentation broth by gas stripping, *Chemical Engineering Transactions*, 49, 13-18.
- Luo H., Bildea C. S., Kiss A. A., 2015, Novel heat-pump-assisted extractive distillation for bioethanol purification, *Industrial & Engineering Chemistry Research*, 54, 2208-2213.
- Luyben W.L., 2017, Improved plantwide control structure for extractive divided-wall columns with vapor recompression, *Chemical Engineering Research and Design*, 123, 152-164.
- Patrascu I., Bildea C. S., Kiss A. A., 2017, Eco-efficient butanol separation in the ABE fermentation process, *Separation and Purification Technology*, 177, 49-61.
- Patrascu I., Bildea C. S., Kiss A. A., 2017, Dynamics and control of a heat pump assisted extractive dividing-wall column for bioethanol dehydration, *Chemical Engineering Research and Design*, 119, 66-74.
- Patrascu I., Bildea C. S., Kiss A. A., 2018, Eco-efficient downstream processing of biobutanol by enhanced process intensification and integration, *ACS Sustainable Chemistry & Engineering*, 6, 5452-5461.
- Salemme L., Olivieri G., Raganati F., Salatino P., Marzocchella A., 2016, Analysis of the energy efficiency of some butanol recovery processes, *Chemical Engineering Transactions*, 49, 109-114.
- Sanchez-Ramirez E., Quiroz-Ramirez J. J., Hernandez-Castro S., Segovia-Hernandez J. G., Kiss A. A., 2017, Optimal hybrid separations for intensified downstream processing of biobutanol, *Separation and Purification Technology*, 185, 149-159.
- Tashiro Y., Yoshida T., Noguchi T., Sonomoto K., 2013, recent advances and future prospects for increased butanol production by acetone-butanol-ethanol fermentation, *Engineering in Life Sciences*, 13, 432-445.
- Xue C., Zhao J-B., Liu F-F., Lu C-G., Yang S-T., Bai F-W., 2013, Two-stage in situ gas stripping for enhanced butanol fermentation and energy-saving product recovery, *Bioresource Technology*, 135, 396-402.