

# Simulation of an SO<sub>2</sub> Tolerant Amine Based Post-combustion CO<sub>2</sub> Capture Process

Ashleigh Cousins<sup>a,\*</sup>, Graeme Puxty<sup>b</sup>, Pauline Pearson<sup>c</sup>, Ralph Weiland<sup>d</sup>, Bharti Garg<sup>e</sup>, Kangkang Li<sup>b</sup>, Vince Verheyen<sup>e</sup>, Paul Feron<sup>b</sup>

<sup>a</sup>CSIRO Energy, Pullenvale, Brisbane, QLD, Australia

<sup>b</sup>CSIRO Energy, Newcastle, NSW, Australia

<sup>c</sup>CSIRO Energy, Clayton, Melbourne, VIC, Australia

<sup>d</sup>Optimised Gas Treating, Texas, USA

<sup>e</sup>Federation University Australia, Churchill, VIC 3842, Australia

[ashleigh.cousins@csiro.au](mailto:ashleigh.cousins@csiro.au)

Removal of multiple contaminants from flue gas streams in a single process step offers the potential to lower the cost of emissions reduction technologies. An example is the CS-Cap process, developed by CSIRO, which removes both the SO<sub>2</sub> and CO<sub>2</sub> from combustion flue gases. In order to further develop this process, a rate based simulation is required of not only the CO<sub>2</sub> capture section, but also the absorption of SO<sub>2</sub> into aqueous amine absorbents. ProTreat® simulation software was used to simulate CSIRO's Loy Yang CO<sub>2</sub> capture pilot plant. This pilot plant has previously been used for proof-of-concept operation of the CS-Cap process. The model simulates various scenarios and flue gas conditions to determine the effect on the operating requirements of the SO<sub>2</sub> capture stage. It reveals that the recirculating absorbent flow rates required in the SO<sub>2</sub> capture loop are of similar magnitude to those required in the CO<sub>2</sub> capture stage. Manipulating the operating parameters of the SO<sub>2</sub> capture section will affect the properties, particularly sulfate concentration, of the slip stream sent for disposal/treatment. This could potentially allow the properties of the waste stream to be tailored for the particular downstream treatment used. In addition, condensation of water from the inlet flue gas stream is identified as an issue requiring further investigation.

## 1. Introduction

In order to meet the Paris agreement to limit global warming to well below 2 °C above pre-industrial levels, Carbon Capture and Storage (CCS) technologies will be required (IEA 2017). There are a number of technologies available for capturing CO<sub>2</sub> (and other greenhouse gas) emissions from industry and power generation. The most technologically advanced of these processes is post combustion capture (PCC) of the CO<sub>2</sub> in an absorption/desorption process using alkanolamines. One of the major challenges facing implementation of PCC technologies, is the high cost (particularly capital) and energy penalty imposed on the host power station (Cormos et al. 2013).

A potentially lower cost method for removing CO<sub>2</sub> emissions from the power sector is the concept of combined capture, i.e. removing 2 or more components from the flue gas stream in a single process step. When amine absorbent based PCC is applied to coal-fired power stations, one of the challenges is the requirement to remove other acid gases, such as SO<sub>2</sub>, from the flue gas prior to the CO<sub>2</sub> capture unit. The absorbed SO<sub>2</sub> forms a stronger acid than CO<sub>2</sub>, and is not regenerated at the conditions typically employed for CO<sub>2</sub> stripping. If not removed from solution, absorbed SO<sub>2</sub> will build up in the absorbent, lowering its ability to capture CO<sub>2</sub>. As a result, most amine based CO<sub>2</sub> capture systems require upstream removal of SO<sub>2</sub> to low levels (typically < 10 ppm). In installations where Flue Gas Desulphurisation (FGD) is currently practiced, this might be achieved by simply adding an additional spray bank to the existing unit. In countries such as Australia, where FGD is not currently employed, adding CO<sub>2</sub> capture also requires the addition of an expensive FGD unit.

Combining the removal of CO<sub>2</sub> and SO<sub>2</sub> from the flue gas stream into a single process unit could provide significant economic savings, particularly for installations that do not currently utilise FGD. Combined CO<sub>2</sub> and

SO<sub>2</sub> capture has been proposed by a few researchers. TNO, in collaboration with CSIRO, have developed the CASPER process, which uses an amino acid absorbent to capture both the CO<sub>2</sub> and SO<sub>2</sub> from a flue gas stream (Misiak et al. 2013). CO<sub>2</sub> is removed from the absorbent via thermal stripping, whilst absorbed sulfur is oxidised to sulfate, and removed via precipitation. This process has been evaluated at pilot-scale, with results feeding into an economic assessment that showed the combined capture process had the potential to lower the cost of CO<sub>2</sub> avoided by 10-20% compared to a standard CO<sub>2</sub> capture process (employing 30 wt% monoethanolamine, MEA) with FGD (Cousins et al. 2014). Another combined capture concept is the Shell-Cansolv process, currently operating at Saskpower's Boundary Dam power station (IEAGHG 2015). In this process an aqueous amine absorbent is used to remove SO<sub>2</sub> in an initial packed column segment. CO<sub>2</sub> is then removed via a second amine absorbent in a subsequent column stage. Both the SO<sub>2</sub> and CO<sub>2</sub> are removed from the absorbent via separate thermal strippers, generating H<sub>2</sub>SO<sub>4</sub> and high purity CO<sub>2</sub> for enhanced oil recovery (EOR).

The CSIRO have developed the CS-Cap process as an alternative low cost multi-component removal process (Meuleman et al. 2012). Here, a single amine absorbent is used to capture both the SO<sub>2</sub> and CO<sub>2</sub> from the flue gas stream, in separate contact stages (Pearson et al. 2017). The development of the process came from early work completed by Beyad et al. (2014) which showed that under controlled laboratory conditions, no SO<sub>2</sub>-amine ('sulfurous acid amide') carbamate equivalent was observed at absorber or desorber temperatures. Further work (Puxty et al. 2014) identified that SO<sub>2</sub> in the flue gas would still readily absorb into CO<sub>2</sub> loaded amine solutions. Proof-of-concept of this process was achieved by utilising a CO<sub>2</sub> rich amine absorbent to capture SO<sub>2</sub> from the flue gas at a brown coal-fired power station. The CO<sub>2</sub> rich amine absorbent readily absorbed SO<sub>2</sub> from the flue gas until it became saturated. At that point the pH of the solution was noted to drop rapidly, and break-through of SO<sub>2</sub> into the flue gas exiting the column was observed (Pearson et al. 2017).

To further develop the CS-Cap process it is important to complete a rate-based simulation so that the effect of operating parameters on the effectiveness of the process can be explored. Additionally, coal fired power station flue gases can contain significant water content. Where upstream treatment (e.g. FGD) is not used, the temperature of the flue gas into the SO<sub>2</sub>/CO<sub>2</sub> capture process could be high. If this is the case, then cooling of the flue gas within the capture process, and condensation of its water content, may occur. It is also important to understand how this dilution could affect the sulfur-rich stream destined for reclamation. ProTreat® is capable of simulating the absorption of both CO<sub>2</sub> and SO<sub>2</sub> into aqueous amines as rate based processes. A model of the SO<sub>2</sub> absorption section of the CS-Cap process has been built in ProTreat®. This model was then used to explore: (1) the influence of inlet flue gas properties, namely SO<sub>2</sub> concentration, on the operating requirements of the SO<sub>2</sub> capture loop, and; (2) the effect of condensed water from flue gas cooling on the process.

## 2. Experimental

### 2.1 ProTreat model

The model of the SO<sub>2</sub> capture loop was built using ProTreat® V6.4. ProTreat® has previously been found to adequately replicate a pilot-scale MEA based CO<sub>2</sub> capture process (Cousins et al. 2012). A sensitivity analysis was performed to determine the effect of increasing column stage calculations on results. Increased stages give greater accuracy, but at increased processing time. 100 stages was determined to be a suitable compromise, bearing in mind that the results presented here are meant to provide insight into operating conditions, and not detailed design. The ProTreat® flow diagram of the model is provided in Figure 1. Flue gas enters the SO<sub>2</sub> absorption column through line 1, and exits via line 2. CO<sub>2</sub> rich absorbent from the CO<sub>2</sub> capture section enters through line 14 (27.1 wt% MEA, 0.5 molCO<sub>2</sub>/molMEA). Previous pilot-scale operation has shown that SO<sub>2</sub> absorbed into amine absorbents under the high O<sub>2</sub> environment found in flue gas based CO<sub>2</sub> capture conditions is rapidly oxidised to sulfate (Reynolds et al. 2012, IEAGHG 2012). As such a component splitter was added to remove 95% of the SO<sub>2</sub> from solution, replacing it with sulfate through Inlet-3. A flow multiplier was used to match the inlet sulfate molar flow rate to the exiting SO<sub>2</sub> molar flow rate. Line 5 (Outlet-2) is the excess stream, which will be sent for reclamation (S removal).

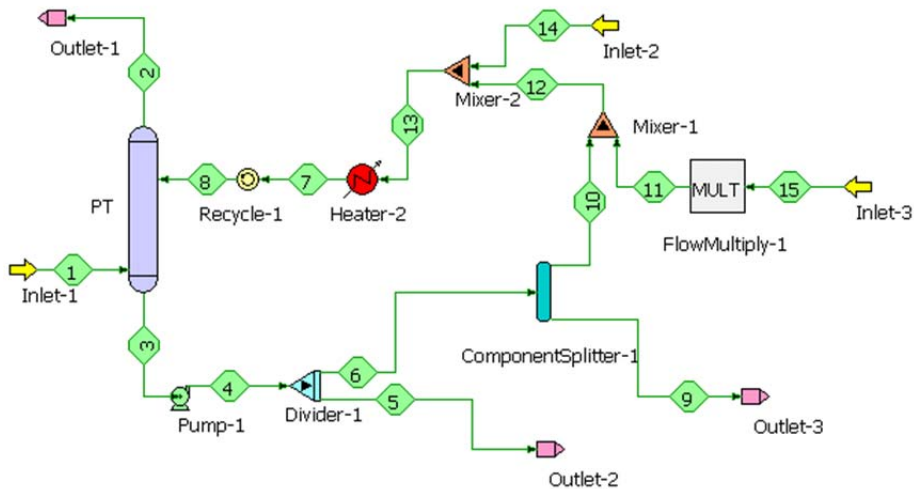

Figure 1: ProTreat model of the CS-Cap process SO<sub>2</sub> capture loop

## 2.2 Effect of flue gas SO<sub>2</sub> concentration and CO<sub>2</sub> rich absorbent inlet stream

To investigate the effect of the CO<sub>2</sub> rich absorbent inlet stream, different flowrates were added to the system through stream 14 (Inlet-2). The effect of flue gas SO<sub>2</sub> concentration was also observed by simulating flue gas with two different SO<sub>2</sub> concentrations: 200 ppmV (a 'typical' SO<sub>2</sub> concentration as observed at the Loy Yang CO<sub>2</sub> capture pilot plant) and 600 ppmV (a 'maximum' SO<sub>2</sub> concentration observed at the pilot plant). For the base case simulations, the temperature of the recirculating absorbent in the SO<sub>2</sub> capture loop was altered to ensure no gain or loss of water from the system.

## 2.3 Effect of flue gas condensation

As flue gas from coal-fired power stations can be saturated, it is possible for condensation of water to occur, particularly for brown coal or lignite flue gases. Hence the simulations were repeated with the inlet flue gas temperature increased to 60 °C, and the recirculating absorbent temperature fixed at 40 °C. The flue gas stream was fully saturated for both cases. The effect of water condensing out of the flue gas into the SO<sub>2</sub> capture loop was then observed for flue gas containing 200 ppmV SO<sub>2</sub>.

The total standard flue gas volume flow (and hence SO<sub>2</sub> molar flow) entering the plant was held constant. As such, a slightly lower mass flow entered the SO<sub>2</sub> capture loop for the 60 °C scenario. The dry gas composition was also held constant. However, due to the higher water content of the 60 °C case, the total concentration of the other components decreased (see Table 1).

## 2.4 Description of Loy Yang CO<sub>2</sub> capture pilot plant

Proof-of-concept operation of the CS-Cap process was completed at CSIRO's CO<sub>2</sub> capture pilot plant at the AGL Loy Yang power station (Pearson et al. 2017). As such, the details of this pilot plant were entered into the model for the simulations. This pilot plant has been described in detail previously (Artanto et al. 2012). In the proof-of-concept experiments, the caustic solution in the pre-treatment column was replaced by a CO<sub>2</sub> rich MEA solution. This solution was operated in batch-mode, recirculating in the pre-treatment system until breakthrough of SO<sub>2</sub> into the flue gas leaving the pre-treatment column was observed. These experiments highlighted the ability of CO<sub>2</sub> rich MEA to quickly remove SO<sub>2</sub> from the inlet flue gas. This also provided a sulfur-rich absorbent solution that has been used in subsequent reclamation experiments.

The pre-treatment column of the Loy Yang pilot plant is 314 mm in diameter and contains 1 m of 5/8" Pall ring packing material made from 304 grade stainless steel. Flue gas from the power station was cooled in an upstream cooler to minimise condensation of water in the pre-treatment system. Flue gas inlet conditions used in the simulations are provided in Table 1. The N<sub>2</sub> concentration was adjusted to account for the 2 different SO<sub>2</sub> concentrations evaluated.

Table 1: Flue gas properties

	Unit	Case		
		Base Case	High inlet SO <sub>2</sub> concentration	High inlet temperature
Temperature	°C	40	40	60
Pressure	kPa-a	103	103	103
Flow rate	m <sup>3</sup> /h	100	100	106.3
Flow rate	kg/h	116.8	116.9	110.8
Concentration				
H <sub>2</sub> O	mol%	7.24	7.24	19.51
CO <sub>2</sub>	mol%	12.06	12.06	10.46
SO <sub>2</sub>	mol%	0.02	0.06	0.02
N <sub>2</sub>	mol%	74.19	74.15	64.38
O <sub>2</sub>	mol%	6.49	6.49	5.63

### 3. Results

#### 3.1 Effect of flue gas SO<sub>2</sub> concentration and CO<sub>2</sub> rich absorbent inlet stream

When operating with 30 wt% MEA, lean absorbent flow rates between 4 - 10 L/min are standard for the CO<sub>2</sub> capture loop of the Loy Yang pilot plant. For this simulation, a lean absorbent flow rate of 5 L/min was assumed in the CO<sub>2</sub> capture loop, with split streams between 0.5 to 10% diverted to the SO<sub>2</sub> capture loop. The recirculation flow rate in the SO<sub>2</sub> capture loop was then altered until a SO<sub>2</sub> concentration of 10 ppmV in the flue gas leaving the SO<sub>2</sub> capture section was achieved. Figure 2 shows the effect of varying the CO<sub>2</sub> rich absorbent slip stream flow rate on the recirculation flow rate required, and pH and wt% sulfate achieved in the SO<sub>2</sub> rich stream sent for reclamation.

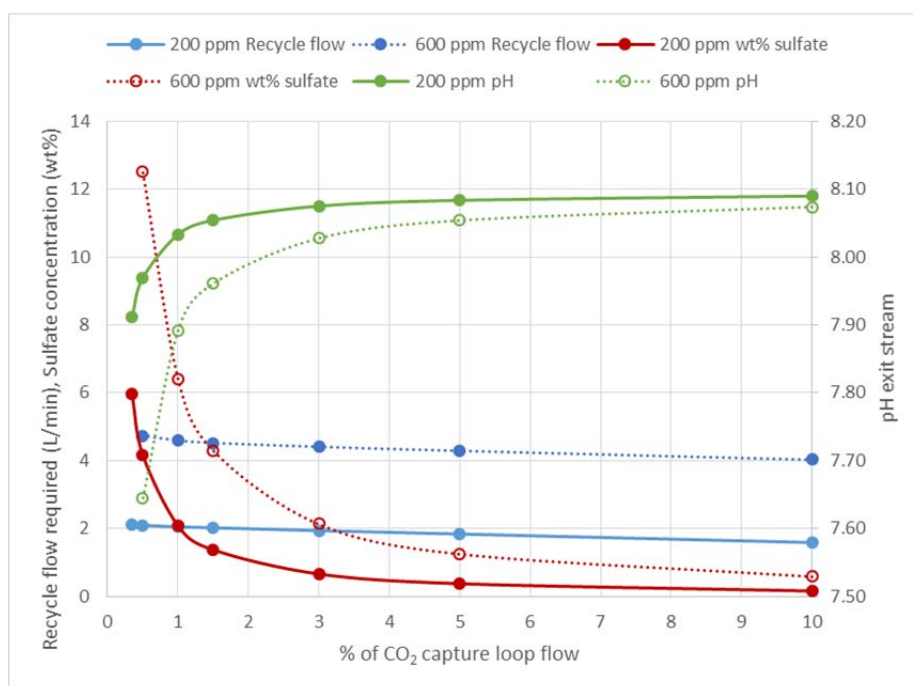

Figure 2: Effect of CO<sub>2</sub> rich inlet flow on SO<sub>2</sub> loop recirculation flow rate, pH, and wt% sulfate of SO<sub>2</sub> rich stream sent for reclamation. Simulations completed for inlet flue gas SO<sub>2</sub> concentrations of 200 and 600 ppmV

As can be seen in Figure 2, a smaller flow rate of CO<sub>2</sub> rich absorbent entering the SO<sub>2</sub> capture loop results in an increase in recirculation flow rate and wt% sulfate, and a drop in pH. A higher flow rate, wt% sulfate and drop in pH are also observed as the concentration of SO<sub>2</sub> in the inlet flue gas increases. As breakthrough was not obtained here, full saturation was not achieved nor the low pH conditions observed during the pilot plant trials completed at AGL Loy Yang (sulfate concentration up to 11.5 wt%, pH drop to ~4, see Pearson et al. 2017). The simulations also show how the slip stream of CO<sub>2</sub> rich absorbent affects the concentration of

sulfate in the absorbent sent for reclamation (note, the temperature of the re-circulating absorbent was altered here to ensure no gain or loss of water in the SO<sub>2</sub> capture column). The final operating conditions of the CS-Cap process will be a trade-off between increased corrosion from lower pH, larger equipment to deal with higher re-circulating absorbent, and increased concentration of sulfate in the absorbent stream to be treated. The recirculating absorbent flow rate is of comparable magnitude to the flow rate in the CO<sub>2</sub> capture loop (1.6 – 4.7 L/min in the SO<sub>2</sub> loop compared to 4 – 10 L/min in the CO<sub>2</sub> capture loop). As the SO<sub>2</sub> capture section will likely have a similar diameter column to the CO<sub>2</sub> capture section (as treating similar volume of flue gas), it is likely similar absorbent flow rates will be required to achieve complete wetting of the packing and stable plant operation. This may be the final determinant in acceptable recirculation flow in the SO<sub>2</sub> capture section.

### 3.2 Effect of flue gas condensation

When CO<sub>2</sub> capture is applied to a coal flue gas, significant volumes of water can be generated as a result of flue gas cooling. If an upstream cooling unit is not provided, then it is possible for condensation to occur within the SO<sub>2</sub> capture loop of the CS-Cap process. This was explored here by increasing the flue gas inlet temperature to 60 °C (fully saturated), and holding the recirculating absorbent temperature constant at 40 °C. These results are provided in Figure 3. A constant standard volumetric flow was maintained between the different simulations. This resulted in a slightly lower total mass flow rate entering the system for the 60 °C case due to the higher concentration of water (see Table 1). The SO<sub>2</sub> molar flow rate entering the facility was the same for all cases.

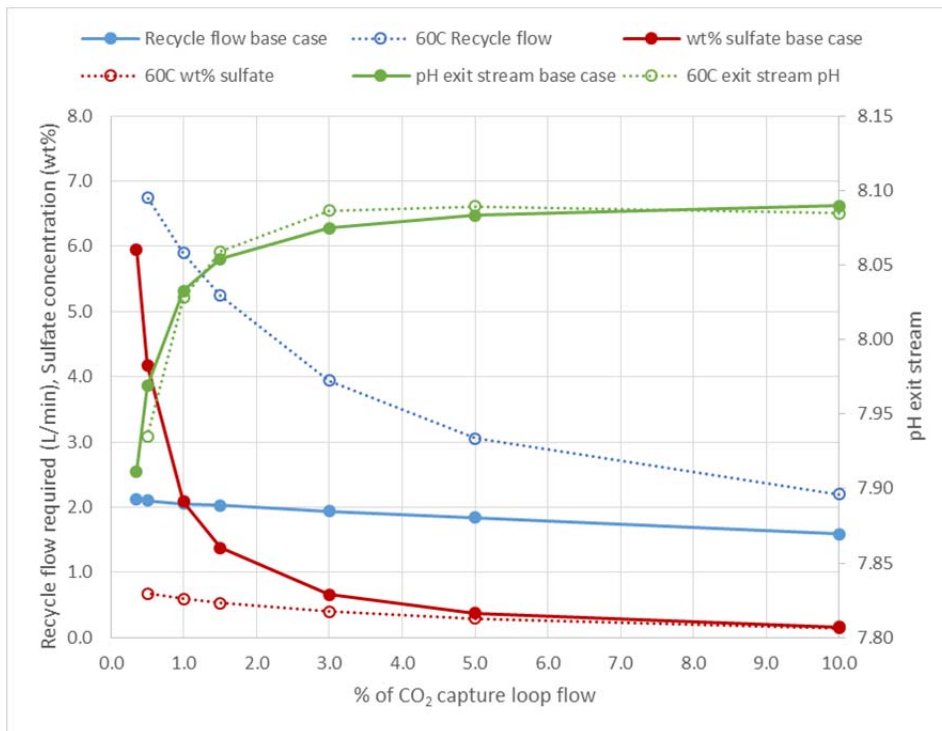

Figure 3: Effect of flue gas inlet temperature (40 and 60 °C) on SO<sub>2</sub> capture loop of the CS-Cap process. Simulations completed with inlet flue gas SO<sub>2</sub> concentration of 200 ppmV

As can be seen in Figure 3, cooling the flue gas in the SO<sub>2</sub> capture loop results in an increase in the recirculating flow rate required in the column. In addition, the water condensed out of the flue gas stream causes the drain stream (sent to reclamation) to increase, with the wt% sulfate decreased as a result of dilution. This could have a significant impact on the effectiveness of the reclamation methods employed. This simulation shows quite clearly the impact if flue gas cooling is not employed. Condensation of water from the flue gas can be quite substantial, particularly if the process is applied to a lignite power station. This could necessitate the addition of a large cooling unit upstream of the CS-Cap process, increasing overall capital costs. An economic evaluation is required to determine if CS-Cap combined with upstream cooling is still competitive compared to the standard PCC process coupled with FGD. Note, upstream cooling may still be required after FGD for the standard case (typical FGD exit temperature 60 °C, CO<sub>2</sub> absorption operating temperature typically 40 °C). Alternatively, the SO<sub>2</sub> capture loop could potentially be run at higher

temperatures, shifting the condensation of water to the CO<sub>2</sub> capture section. The excess water condensed from the flue gas could be removed in the CO<sub>2</sub> stripping column. This would add an energy penalty to the CO<sub>2</sub> capture process, but could be beneficial if an additional water source is advantageous. At the Boundary Dam CO<sub>2</sub> capture plant, an upstream cooler is used to condense water out of the flue gas prior to the SO<sub>2</sub> absorption column. The condensed water is sent to the water treatment plant and is used as make-up.

#### 4. Conclusions

A rate-based simulation of SO<sub>2</sub> removal from a coal flue gas was built using the ProTreat® simulation software. This model was used to investigate the effect of operating conditions on the SO<sub>2</sub> capture loop of the CS-Cap process. The simulations highlighted the effect of flue gas SO<sub>2</sub> concentration, and CO<sub>2</sub> rich absorbent inlet flow rate on the operating conditions required to maintain the SO<sub>2</sub> concentration in the exiting flue gas below 10 ppmV. The recirculating flow rate required in the SO<sub>2</sub> absorption loop was of similar magnitude to the absorbent flow rate used in the CO<sub>2</sub> capture section of the pilot plant simulated. This bodes well for the process as similar diameter columns would likely be required in the SO<sub>2</sub> and CO<sub>2</sub> capture sections as a similar volume of flue gas will require treating. One issue that will need to be explored further is the potential for condensation of water from the inlet flue gas stream into the SO<sub>2</sub> capture loop. This condensation increases the recirculating flow rate in the column and dilutes the stream sent for reclamation. Any dilution will likely reduce the efficiency of the reclamation process used.

#### Acknowledgments

The authors wish to acknowledge financial assistance provided by Brown Coal Innovation Australia Limited, a private member-based company with funding contracts through Australian National Low Emissions Coal Research and Development Ltd (ANLEC R&D) and the Victorian State Government.

#### References

- Artanto, Y., Jansen, J., Pearson, P., Do, T., Cottrell, A., Meuleman, E., Feron, P., 2012, Performance of MEA and amine-blends in the CSIRO PCC pilot plant at Loy Yang Power in Australia, *Fuel*, 101, 264-275
- Beyad, Y., Puxty, G., Wei, S., Yang, N., Maeder, M., Burns, R., Meuleman, E., Feron, P., 2014, An SO<sub>2</sub> tolerant process for CO<sub>2</sub> capture, *International Journal of Greenhouse Gas Control*, 31, 205-213
- Cormos, C.C., Cormos, A.M., Agachi, P.S., Assessment of carbon capture options for super-critical coal-based power plants, *Chemical Engineering Transactions*, 35, 367-372
- Cousins, A., Artanto, Y., Meuleman, E., Pearson, P., Puxty, G., Jansen, J., Conway, W., Slater, N., Curtis, E., Monch, A., Feron, P., Verheyen, V., Misiak, K., Huizinga, A., Sanchez Sanchez, C., van Os, P., Goetheer, E., Castelow, P., 2014 Combined low-cost pre-treatment of flue gas and capture of CO<sub>2</sub> from brown coal-fired power stations, *Proceedings Low Rank Coal 3<sup>rd</sup> International Industry Symposium*
- Cousins, A., Cottrell, A., Lawson, A., Haung, S., Feron, P., 2012, Model verification and evaluation of the rich-split process modification at an Australian-based post combustion CO<sub>2</sub> capture pilot plant, *Greenhouse Gases Science and Technology*, 2, 329-345
- IEA, 2017, *Energy Technology Perspectives*, Paris, France
- IEAGHG, 2012, *Emissions of substances other than CO<sub>2</sub> from power plants with CCS*, Cheltenham, UK
- IEAGHG, 2015, *Integrated carbon capture and storage project at Saskpower's Boundary Dam power station*, 2015/06, August 2015, Cheltenham, UK
- Meuleman, E., Puxty G., Feron, P., 2012, Process for capturing acid gases, Patent No. WO 2012097406
- Misiak, K., Sanchez Sanchez, C., van Os, P., Goetheer, E., 2013, Next generation post-combustion capture: Combined CO<sub>2</sub> and SO<sub>2</sub> removal, *Energy Procedia*, 37, 1150-1159
- Pearson, P., Moscatelli, J., Garg, B., Cousins, A., Meuleman, E., Puxty, G., Verheyen, V., Feron, P., 2017, An update on the development of the CSIRO's CS-Cap combined CO<sub>2</sub> and SO<sub>2</sub> capture process, *Energy Procedia*, 114, 1721-1728
- Puxty, G., Wei, S., Feron, P., Meuleman, E., Beyad, Y., Burns, R., Maeder, M., 2014, A Novel process concept for the capture of CO<sub>2</sub> and SO<sub>2</sub> using a single solvent and column, *Energy Procedia*, 63, 703-714
- Reynolds, A., Verheyen, T., Adeloju, S., Meuleman, E., Feron, P., 2012, Towards commercial scale post combustion capture of CO<sub>2</sub> with Monoethanolamine solvent: Key considerations for solvent management and environmental impacts, *Environmental Science and Technology*, 46, 3643-3654