



Hydrodynamics of a Packed Column Operated under Supercritical Conditions

Hendrik H. Franken, Johannes H. Knoetze, Cara E. Schwarz*

Department of Process Engineering, Stellenbosch University, Private Bag X1, Matieland, 7602, South Africa
cschwarz@sun.ac.za

There is a lack of hydrodynamic data under supercritical conditions, in particular in systems that attempt to isolate hydrodynamics from mass transfer. This paper presents hydrodynamic data focusing on the characterization of flooding. Two different flooding phenomena are identified using the column overheads, pressure drop and liquid hold-up of the system. It is further noted that the saturated fluid properties of density and dynamic viscosity play a significant role in flooding. A density difference of less than 250 kg/m^3 between phases and a decrease in liquid viscosity causes a shift from classical gas-liquid flooding to behaviour more analogous to that of liquid-liquid extraction columns.

1. Introduction

Supercritical fluids (SFs) are increasing in popularity as a solvent for various extraction and absorption processes. Presenting an attractive alternative to traditional solvents, SFs are readily tuneable and capable of sharp, highly efficient separations while using less intrinsically harmful solvents. The application of the technology is however hampered by a lack of design methods and predictive models (Schwarz, Knoetze, 2009). To develop these methods a fundamental understanding of the mass transfer and transport phenomena in SF systems is required. Mass transfer operations in SFs is widely investigated in the literature, with phase equilibria providing insight into the operating pressure, temperature, and driving force for separation (Seader, Henley, 2013). Additionally, several EOS (Equation of State) models capable of reasonable predictions of phase equilibria under SF conditions exist in the literature (Lombard, 2015). However, data and models for physical properties and transport phenomena under SF conditions are decidedly scarcer. Consequently, no comprehensive, predictive hydrodynamic models for columns operating under SF conditions exist. This deficiency forces the extensive piloting of any new applications and significant overdesign of equipment to compensate for the lack of knowledge. A thorough study of the effect of fluid properties on the hydrodynamics of SF systems is required to address this shortcoming, allowing the creation of a knowledge base from which such models can be developed.

The available literature is very diverse and does not typically focus solely on hydrodynamics. Rathkamp et al. (1987), researched the efficiency and energy requirements of columns operating with supercritical CO_2 using a water/EtOH system in a 25.4 mm column packed with 6.4 mm metal Raschig rings. Seibert and Moosberg (1988) measured efficiency and liquid hold-up using a 98.8 mm column with sieve trays, 12.7 mm Raschig rings and #15 IMTP using a water/EtOH system. Sievers (1994) and Woerlee (1997) were among the first to measure flooding under SF conditions, using water and hexadecane respectively, in a 36 mm column packed with a gauze type packing, Montz-Pak type A3. Both authors explicitly state that SF hydrodynamics are not consistent with generalised pressure drop correlations of the time. Lim et al. (1995) investigated liquid hold-up in a 31.8 mm column with a knit mesh packing. They observed a positive correlation between a rise in system pressure and a rise in the liquid hold-up. Machado (1998) measured flooding points consistent with the work of Woerlee (1997), using palm oil distillate in a 25 mm column, packed with Sulzer EX. Meyer (1998), using the same experimental setup, measured not only flooding but also the pressure drop and physical properties of soybean oil/ CO_2 and fish oil/ CO_2 systems. Meyer (1998) compared his results with well-known flood point correlations (Mersmann, 1965; Eckert, 1970; Maćkowiak, 1991) and concluded that models derived for vacuum- and lower pressure application do not readily predict high-pressure systems ($P > 70 \text{ bar}$). Buddich

(1999) and Buddich and Brunner (1999), again using the same experimental setup, investigated orange peel oil/CO₂ and water/ethanol/CO₂ systems. Stockfleth and Brunner (1999; 2001) were the first and only to perform a full hydrodynamic study, investigating liquid hold-up, flooding, pressure drop and foaming for water/CO₂, olive oil distillate/CO₂ and tocopherol/CO₂ systems. Modifying the semi-empirical models proposed by Stichlmair et al. (1989), they achieved relative success in empirically predicting hydrodynamic phenomena, except for flooding.

To investigate fundamental hydrodynamic behaviour, systems with quantified mass transfer and known fluid properties are required. Firstly, mass transfer directly affects effective fluid flow rates and fluid properties, complicating the interpretation of hydrodynamic results. The limited available literature on SF hydrodynamics has neglected the effect of mass transfer or used systems with fluid properties either undefined or very different from that of a typical, commercially relevant system. Secondly, the fluid properties of density and dynamic viscosity are particularly important, as these properties are highly variable with changes in mixture composition, pressure and temperature under SF conditions (Franken et al., 2018a). This variability implies that small variations in pressure and temperature can significantly affect hydrodynamics. Further, this fluid property variability causes large deviations from predictions using atmospheric fluid properties. Fluid properties can also not easily be predicted under SF conditions using standard models (Brunner, 1994).

No collection of literature sources cover all the required aspects of a suitable system, presenting both phase equilibria data and phase properties. Therefore, a binary system with suitable phase behaviour was identified, and its fluid properties, specifically density and dynamic viscosity, were measured in a preceding study (Franken et al. 2018b). CO₂, as the most popular SF solvent, was used with 100 cSt PDMS (poly[dimethylsiloxane]) as the liquid phase. The system proved to exhibit properties in applicable ranges for hydrodynamic study (~900 - 800 kg.m⁻³ and ~0.7 - 7 mPa.s), with only a very low amount of PDMS soluble in the SF phase, minimising mutual solubility and hence eventual mass transfer. The data allow the investigation of hydrodynamics using a system with known fluid properties in ranges similar to that of real SF – solute systems.

This work aims to make use of the aforementioned CO₂ + PDMS 100 system to measure hydrodynamics under SF conditions on a pilot plant scale while minimising mutual solubility. Specifically, the paper focussed on the identification of flooding behaviour by interpreting the liquid percentage in the overheads, the liquid hold-up in the column packing, and the pressure drop over the packing. Further, the influence of the fluid properties on flooding was investigated. Notably, the experiments were performed using random packing, ¼” Dixon Rings, while literature data are only available on structured packings.

2. Materials and methods

2.1 Experimental equipment

A basic process flow diagram of the experimental pilot plant is seen in Figure 1 with a legend in Table 1a and specifications for the pilot plant provided in Table 1b. The pilot plant was assembled in-house and consists of two columns. For the work presented here only the larger diameter column, ID 38mm, was used. The pilot plant can measure the liquid hold-up, pressure drop and column bottom- and overheads rates over a wide range of liquid- and SF solvent flow rates. From these measurements, flooding and entrainment can be identified. Pressure drop is measured using an Endress+Hauser Deltabar S PMD75 pressure transducer with an accuracy of 0.075 % of its range of 50 kPa. Temperature is measured by multiple J type thermocouples, accuracy ±1.5 K. SF mass flow rate is measured using a Micro Motion D12 flow sensor and RFT 9729 remote flow transmitter combo with an uncertainty of 0.2% of the rate. All electronic data are logged using a custom PLC setup. The liquid mass flow rate is determined from prior calibration of the pumps and confirmed by doing a liquid mass balance over the column.

2.2 Materials Used

Details on the chemicals used are available in Table 2. The PDMS used in this study were methyl group capped and effectively linear, with few side chains. Chemicals were used without further treatment or purification. The phase transitions and fluid properties of the CO₂ + PDMS systems were determined in-house using a previously verified variable volume view cell (Franken et al., 2018). Saturation, and hence phase transition, was determined for 1-70 wt% PDMS in CO₂ at 313-353 K using the visual static synthetic method (SynVisVar). The density and dynamic viscosity were measured for both the SF- and solute-rich phases using the quantified volume and mass, and the converse piezoelectric effect, respectively.

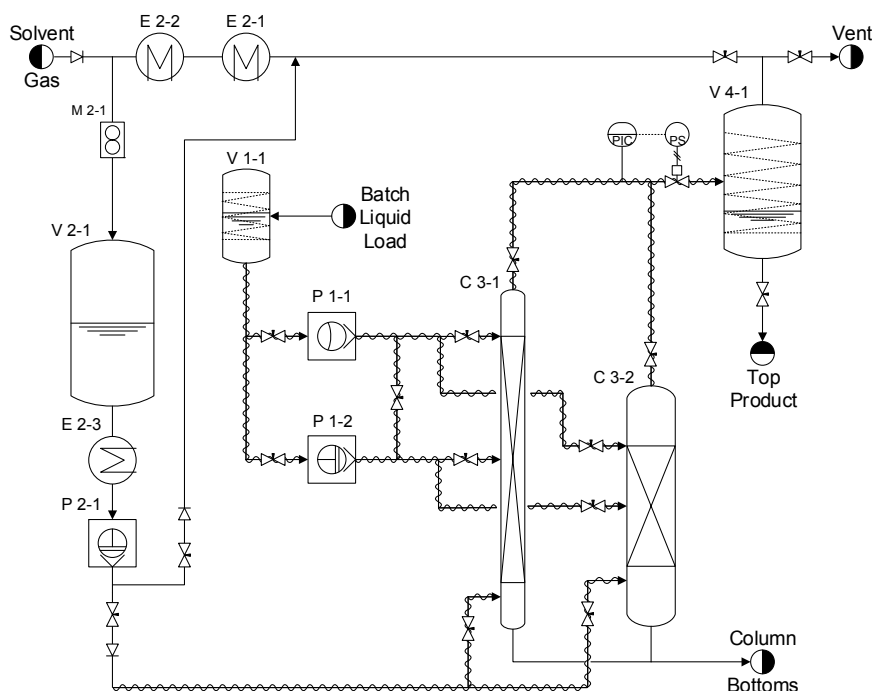

Figure 1: Schematic representation of the pilot plant set-up

Table 1: a) Legend for Figure 1.

Label	Description
V 1-1	Liquid Feed Tank
P 1-1	Small Capacity Diaphragm Pump
P 1-2	Large Capacity Piston Pump
E 2-1	Water Pre-cooler
E 2-2	Chilled Condenser
M 2-1	Mass Flow Meter
V 2-1	Solvent Buffer Tank
E 2-3	Pump Feed Chilled Pre-cooler
P 2-1	Solvent Diaphragm Pump
C 3-1	Small Diameter Column
C 3-2	Large Diameter Column
V 4-1	Overhead Product Separator Vessel

b) Pilot plant specifications.

Description	Values
Maximum system pressure	300 bar
Maximum system temperature	473 K
Separator pressure	~50 bar
Liquid flow rate range	0 - 8 l/h
SF flow rate range	0 - 55 l/h
Column C 3-1 Diameter	17 mm
Column C 3-1 Packed Height	3.5 m
Column C 3-2 Diameter	38 mm
Column C 3-2 Packed Height	1.5 m
Column Packing	1/4" Dixon Rings
Packing void fraction	91 %
Packing surface area	900 m ² /m ³

Table 2: Chemicals used in this study.

Chemical	Purity	Supplier
CO ₂	99.9999%	Air Products
PDMS 100	Absolute	Xiameter PMX-200 (DOW Corning)

2.3 Experimental considerations and procedure

Pressure and temperature considerations

With an array of possible testing conditions, careful selection of the experimental conditions was required to ensure mass transfer is limited and the physical properties fall in the desired ranges. Experiments were performed at 14 MPa to simplify the problem. This pressure ensured that the solubility of the PDMS into the SF phase is very low ($\ll 1$ wt%) and the SF phase properties are effectively the same as that of pure CO₂ at the same pressure and temperature. CO₂ solubility into the PDMS at these conditions is significant (~30 - 40 wt%), and must be taken into consideration. An experimental temperature of 333.15 K was selected as a starting point, with the temperature lowered in 5 K intervals for every subsequent experimental set. This decrease was continued until the column becomes inoperable due to flooding. Each change in temperature lead to a change in density of the CO₂ and density and viscosity of the liquid.

Dry pressure drop

Before the packing was wetted, the dry bed pressure drop was measured. This measurement was done by operating the column with only SF CO₂ flow. After reaching stable, equilibrium flow, as indicated by a stable pressure drop over the column, the pressure drop was noted. The SF flow rate was then changed and time was allowed to ensure a new equilibrium (~30 Minutes). This procedure was repeated to provide dry pressure drop data over a full range of SF flow rates, after which the temperature was changed and the process repeated until all the required experimental conditions were investigated.

Wet pressure drop and liquid hold-up

For a single liquid / SF flow rate combination, the column was first operated only with SF CO₂. After the column reached equilibrium with SF flow alone, the pressure drop over the column was noted, and the liquid feed started at a pre-calibrated rate. The column was then allowed to reach a new equilibrium, after which the pressure drop over the column was noted. All flow to the column was then shut off, with the pressure drop immediately after the shutdown noted and the hold-up diverted to separate it from the bottoms. After allowing for sufficient time for all of the liquid hold-up to drain the column bottoms, tops and liquid hold-up were decanted and weighed. The flow rate combination and/or temperature is then changed as desired, after which the process was repeated to gather further data. The pressure drop reported here is the difference between equilibrium value of the SF flow alone, subtracted from the maximum equilibrium value.

3. Results And Discussion:

As the aim of this paper is to provide insight into the qualitative trends and phenomena, only representative results illustrating flooding are presented. Full sets of hydrodynamic data have been measured for 2 separate PDMS liquids and are reported elsewhere (Franken 2018).

3.1 Dry pressure drop

Measurements of the dry pressure drop behaviour of the packing are presented for 313.15 K, as seen in Figure 2a. A model prediction is performed using a modified Ergun-type equation (Stichlmair et al., 1989), with determined constants $K_1 = 459$ and $K_2 = 4.11$. These constants are of the same order of magnitude as that determined by Stockfleth and Brunner (2001). It is seen that the model predicts the data well, as expected with a fitted, semi-empirical equation. It is however of value to see that the data fall comfortably within a $\pm 20\%$ confidence interval of the model, indicating the pilot plant stability and repeatability.

3.2 Flooding determination

There is no universal definition for flooding, and many of the definitions available in the literature are vague, impractical or arbitrary (Kister, 1992). Flooding is defined for this work as the total hydrodynamic inoperability of a column, or, in other words, the point after which a column ceases to be an effective vessel for separation. This operability is determined by monitoring the mass fraction of liquid in the overheads, the pressure drop and the liquid hold-up. Typically flooding is accompanied by a sharp, sudden increase in the percentage of liquid overheads. A significant wt% increase (>80% of the value) above the saturation of the fluid was deemed a possible indication of flooding, with further investigation into the pressure drop and liquid hold-up used to confirm. An example of this can be seen in Figure 2b, with unfilled markers indicating flooding from here on.

Two types of flooding behaviour were identified. Firstly, flooding was observed that caused an increase in both the liquid percentage of the overheads, liquid hold-up and the pressure drop, with an increase in liquid feed rate. This type of flooding was found at high liquid rates and low SF flow rates and characteristically exhibited an intermittent, rapid rise and fall in the pressure drop of the column under 'equilibrium' conditions. This pressure instability is thought to be an indication of 'slugging' behaviour, with a continuous liquid phase layer forming in the column. This continuous liquid phase is then intermittently pushed out of the column by slugs of the SF phase rising through it. Alternatively, the liquid layer can build up high enough in the column to start exiting through the overheads. A large amount of liquid in the column would also correspond to a relatively higher pressure drop and higher liquid hold-ups before the column becomes inoperable. This behaviour can be seen in Figure 3a for the liquid hold-up of the 12.7 mm/s gas velocity system, showing a gradual increase in the hold-up followed by eventual flooding. Similar behaviour was observed for the pressure drop, omitted here due to spatial constraints. This behaviour is similar to flooding in a 'classical' gas-liquid extraction column and agrees with the data gathered by Franken (2014) for the system Polyethyleneglycol + CO₂.

in

the

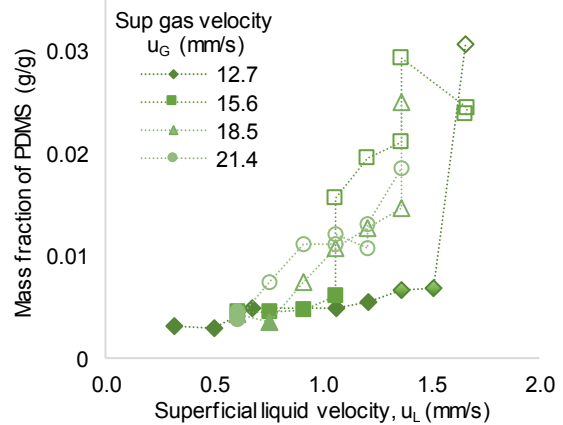
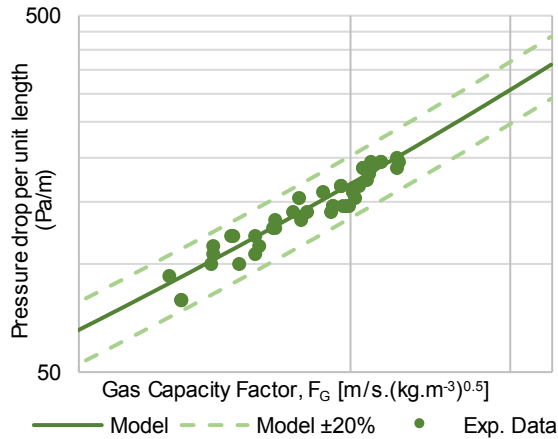

Figure 2: a) Dry pressure drop and model prediction at 14 MPa and 313.15 K for ¼" Dixon Rings and SF CO₂.

b) Mass fraction PDMS 100 in the column overheads at 14 MPa and 313.15 K at various superficial gas velocities

Secondly, flooding was identified that caused an increase in the liquid percentage in the overheads, a plateau in the liquid hold-up, and a maximum and subsequent decrease in the pressure drop, all concerning an increase in liquid feed rate. This behaviour was noted in medium to high liquid- and SF flow rates, as can be seen for 15.6 - 21.4 mm/s range in Figure 3a for the liquid hold-up. This flooding occurred more readily when the density of the SF phase became similar to that of the saturated liquid, and the liquid dynamic viscosity decreased. The fluid property dependence is better seen in Figure 3b, where the density difference between the phases varies from ~300 kg/m³, ~250 kg/m³ to ~200 kg/m³ and the viscosity decreases from ~2.86 mPa.s, ~2.48 mPa.s to ~2.11 mPa.s, as the temperature decreases. The smaller difference in phase densities plays a large role in the magnitude of buoyancy forces, while a decrease in the dynamic viscosity increases the mobility of the liquid phase. Together these changes in the fluid properties promote the entrainment of the liquid by the SF phase. This behaviour is more analogous to that found in liquid-liquid extraction columns.

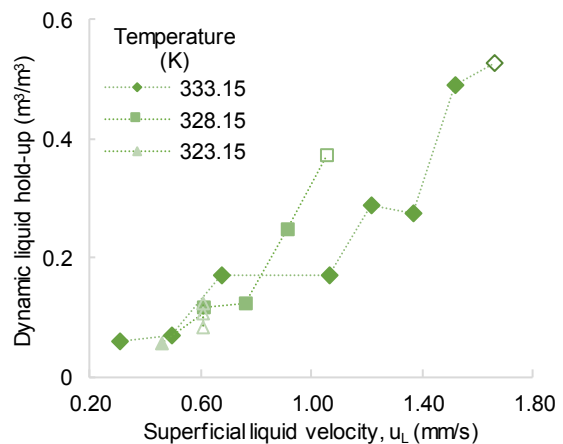
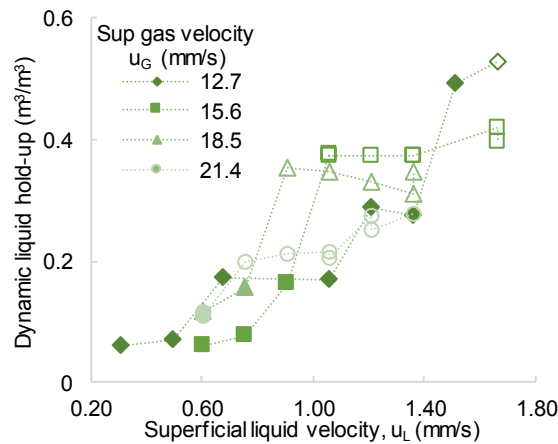

Figure 3: a) Dynamic liquid hold-up at 313.15 K and 14 MPa for CO₂ + PDMS 100.

b) Dynamic liquid hold-up at UG = 12.7 mm/s over three different temperatures for CO₂ + PDMS 100.

4. Conclusions

Pilot plant data were measured to identify flooding of a column with random packing, ¼" Dixon Rings, operated with a system optimised for low mutual mass transfer and fluid properties close to that of actual SF systems, namely CO₂ + 100 cSt PDMS. Flooding was identified using the liquid percentage in the overheads, the liquid hold-up in the column packing, and the pressure drop over the packing. Two different types of flooding phenomena were identified, respectively being analogous to gas-liquid and liquid-liquid columns. The

shift between the flooding phenomena was accompanied by a decrease in the liquid phase viscosity and the density difference between the phases, with a difference in density of less than $\sim 250 \text{ kg/m}^3$ proving significant.

Acknowledgments

This work is based on the research supported in part by the National Research Foundation of South Africa (Grant specific unique reference number (UID) 88782). The authors acknowledge that opinions, findings and conclusions or recommendations expressed in any publication generated by the NRF supported research is that of the authors', and that the NRF sponsors accept no liability whatsoever in this regard.

References

- Brunner, G., 1994, Gas Extraction, An introduction to fundamentals of supercritical fluids and the application to separation processes, Steinkopff, Darmstadt, ISBN: 978-3-662-07382-7.
- Budich, M., 1999, Countercurrent extraction of citrus aroma from aqueous and nonaqueous solutions using supercritical carbon dioxide, Düsseldorf, Düsseldorf, Germany, VDI-Verlag.
- Budich, M., Brunner, G., 1999, Vapour-liquid equilibrium data and flooding point measurements of the mixture carbon dioxide + orange peel oil, *Fluid Phase Equilib.*, 158, 759.
- Eckert, J.S., 1970, Selecting the proper distillation column packing, *Chem. Eng. Prog.*, 66, 39.
- Franken, H.H., 2014, Establishment of a supercritical pilot plant and the hydrodynamics of supercritical countercurrent columns, Masters Thesis, University of Stellenbosch, Stellenbosch, South Africa, Retrieved from: <http://hdl.handle.net/10019.1/95961>
- Franken, H.H., 2018, The Hydrodynamics of Supercritical Countercurrent Columns, PhD Dissertation, University of Stellenbosch, Stellenbosch, South Africa, (to be published Dec 2018).
- Franken, H.H., Knoetze, J.H., Schwarz, C.E., 2018a, Concurrent measurement of high-pressure binary phase equilibrium, density and dynamic viscosity, *J. Supercritical Fluids*, 133, 444
- Franken, H.H., Knoetze, J.H., Schwarz, C.E., 2018b, High-pressure binary phase equilibria, density and dynamic viscosity of 100 & 200 cSt polydimethylsiloxane (PDMS) with supercritical CO₂, *J. Supercritical Fluids*, 139, 1
- Lim, J.S., Lee, Y.-W., Kim, J.-W., Lee, Y.Y., Chun, H.-S., 1995, Mass-transfer and hydraulic characteristics in spray and packed extraction columns for supercritical CO₂-ethanol-water system, *J. Supercrit. Fluids*, 8, 127.
- Kister, H.Z., 1992, Distillation Design, McGraw- Hill, New York, United States of America, ISBN 0-07-034909-6.
- Lombard, J.E., 2015, Thermodynamic modelling of hydrocarbon-chains and light-weight supercritical solvents, Masters Thesis, University of Stellenbosch, Stellenbosch, South Africa, Retrieved from: <http://hdl.handle.net/10019.1/96844>.
- Machado, N.T., 1998, Fractionation of PFAD - compounds in countercurrent columns using supercritical carbon dioxide as solvent, PhD Dissertation, Technische Universität Hamburg – Harburg, Harburg, Germany.
- Maćkowiak, J. 1991, Fluid dynamics of packings and columns with modern packings for gas/liquid systems (orig. German), Salle & Sauerland, Frankfurt, Germany.
- Mersmann, A., 1965, Zur berechnung des flutpunktes in füllkörperschüttungen. *Chem. Eng. Tech.*, 37, 218.
- Meyer, J.-T., 1998, Druckverlust und flutpunkte in hochdruckgegenstromkolonnen, Ph.D. Dissertation, Technische Universität Hamburg, Hamburg, Germany.
- Rathkamp, P.J., Bravo, J.L., Fair, J.R., 1987, Evaluation of packed columns in supercritical extraction process, *Solvent Extr. Ion Exch.*, 3, 367.
- Schwarz, C.E., Knoetze, J.H., 2009, Design of supercritical fluid processes for high molecular mass petrochemicals, In: Belinsky, M.R. (Ed.), *Supercritical Fluids*, Nova Science Publishers, Hauppauge, New York, United States, ISBN: 978-1-60741-930-3
- Seader J.D., Henley, E.J., 2013, Separation Process Principles, 3rd Edition, Wiley, Chichester, ISBN: 978-0-470-48183-7.
- Seibert, A.F., Moosberg, D.G., 1988, performance of spray, sieve tray, and packed contactors for high pressure extraction, *Sep.Sci. Tech.*, 23, 2049.
- Sievers, E.J., 1994, Pressure drop and flooding with a supercritical fluid, PhD Dissertation, Technische Universität Delft, Delft, The Netherlands.
- Stichlmair, J., Bravo, J.L. Fair, J.R., 1989, General model for prediction of pressure drop and capacity of countercurrent gas/liquid packed columns, *Gas Sep. Purif.*, 3, 19.
- Stockfleth, R., Brunner, G., 1999, Hydrodynamics of a packed countercurrent column for the gas extraction, *Ind. Eng. Chem. Res.*, 38, 4000.
- Stockfleth, R., Brunner, G., 2001, Holdup, pressure drop, and flooding in packed countercurrent columns for the gas extraction, *Ind. Eng. Chem. Res.*, 40, 347.
- Woerlee, G.F., 1997, Hydrodynamics and mass transfer in packed columns and their applications for supercritical separations, PhD Dissertation, Technische Universiteit Delft, Delft, The Netherlands.