

Design and Implementation of a Joint Training Program for Chemical Industry Fellows

Olga S. Kukurina^{*a}, Marina E. Trusova^a, Yulia S. Vorotnikova^b, Anna Dell'Angelo^c,
Flavio Manenti^c

^aTomsk Polytechnic University, 30 Lenin Ave, Tomsk, Russia, 634050

^bSIBUR PLC, Moscow, 16/1 Krzhizhanovsky st., Russia, 117218

^cPolitecnico di Milano, Dipartimento di Chimica, Materiali e Ingegneria Chimica "Giulio Natta", 32 Piazza L. Da Vinci, Milan, Italy, 20133

kukurina@tpu.ru; trusova@tpu.ru; vorotnikovayus@tobolsk.sibur.ru

The present paper describes a collaborative experience in the development and realization of a new joint educational program. The great motivation for designing the joint training program is the urgent need for the industrial sector to promote vocational training and enhance the leadership and professional skills of the staff, as well as to build sustainable partnerships between universities and chemical industry fellows.

Therefore, the initiation stage and further implementation of the joint program were supported and facilitated by a business unit manager of Corporate University PJSC SIBUR within the framework of joint cooperation. The employee training under discussion was developed with PJSC SIBUR Holding (the largest petrochemical company in Russia) acting as a stakeholder to meet organizational objectives and participant expectations.

The content of the designing program is indented to strengthen cross-training between background knowledge and technical applicative skills, and is based on the interdisciplinary and cooperative collaboration of Tomsk Polytechnic University and Politecnico di Milano. The key feature of the program under consideration is the use of a project-based approach. In this regard, the curriculum is designed to be flexible and based around term projects where the topics of investigation are suggested and selected by the participants in correlation with their professional duties. Final team project presentation (the attendees perform the deliverables of their project's solution) and a critical review from Sibur's experts are considered as the general assessment tool for this program. It should be mentioned, the deliverables of the performed projects were estimated at a high level by SIBUR experts. During the program implementation period, the following inferences and recommendations can be made: to reconsider the entry test content and requirements (to make them more customized), to raise the requirements towards a command of English. It was also offered to indicate a two-level system of training aimed at selection of the best learners (based on the results of the final task and achievement test completion) who will pursue the second level the focus of which is to introduce a module on computer modeling of specific processes and digital training in Chemical Engineering.

1. Introduction

Over the last decade, there has been a growing understanding among Russian petrochemical industrial societies and educators in the field of chemical engineering that there is a need to transform the academic approach to training programs for employees to achieve a better quality of staff qualifications. In fact, the demand for highly skilled professionals in the engineering sphere serves as a driving force to motivate higher educational institutions to reconsider and optimize current curricula (Cesaroni et al., 2004), to develop innovative educational programs with international participation. Additionally, a shift occurring in Russian economics and society has an impact on the content and structure of engineering degree programs on the whole and chemical engineering programs particularly. The development of a specific program for staff training comprises several directions which involve the search for new formats of industrial-academic cooperation (Yankwich, 1984). Being a curriculum coordinator, one might face problems relating to a shortage

of relevant data and information access on the international experience in the realization of collaborative educational programs for chemical industries.

The design of the program was proceeded by the official inquiry from SIBUR, here is an excerpt. "We [Company] intend to continue developing the main direction of our collaboration in 2019, including a unique educational program in Chemical Engineering, which presents one of the key stages for training young engineers for current and future projects of our company, requiring world-class competencies". Therefore, the goals set during the cooperation are to enhance the skills and to develop competencies in the sphere of modern chemical production engineering, namely, predictive analytics, computer modeling, engineering of catalytic reactions, and thermodynamic processes.

A distinctive feature of the program is seen in the fact that the English language has been used to deliver the content of the program modules both by Russian and Italian university faculties. "One of the reasons for integrating both content and language in the training process is to provide exposure to language without requiring extra time in the curriculum, which can be of particular interest in vocational settings" (Rozanova et al, 2020).

It worth also mentioning that Politecnico di Milano University is included in the rating of the top 50 tertiary institutions in Europe (with seven specializations together with chemical engineering respectively). Since the university–partner is the leading university worldwide and the third party that is engaged in the implementation of the joint training program, the interaction between the industrial and educational sectors is driven to new heights. Collaboration partnership turned out to be beneficial for all parties, specifically, SIBUR has got international expertise in its projects and universities have changed their position from research institutions to comprehensive ones that bridge the gap between industry and education.

1.1 Designing Programme Specification

The first step in developing a training program is to identify a simple and explicit model that meets the requirements of stakeholders. In this case, the most relevant structure is the basic didactic model of Engineering Pedagogy Science (EPS), e.g., Figure 1. This model has been described by (Ruttmann, 2019) based on the student-teacher partnership supported by an interdisciplinary approach and an integrated learning content that follows a precise and logical structure.



Fig. 1 The basic didactic model of Engineering Pedagogy Science (EPS)

The next step is to create a comprehensive action plan that includes learning theory, instructional design, and content. It might deepen the existing background knowledge as well as help to expand engineering literacy among the participants, which allow them to come up with efficient plans and ready solutions for their technical cases.

In so doing, we pay particular attention to the background knowledge of students during the education program design by addressing and bridging the existing gaps. Major problems that students face during the course are related to:

- Analysing the skills of material and energy balance;
- Background in Unit Operations and Processes;
- Applying appropriate mathematical skills;
- Interpreting results from the computational tools applied;
- Selecting an appropriate optimization tool;
- Computer programming skills.

The abovementioned skills acquisition is considered a significant aspect during the period of comprehensive training in the field of Chemical Engineering (Aviso et al., 2018) and any weakness in educational foundations in such concepts can result in poor Process Integration learning outcomes. The importance of the knowledge of specific software and kinetic model building of processes (knowledge of concepts such as objective functions, constraints, solution algorithms, etc.) was highlighted by the industrial partner.

Besides, due attention needs to be paid to Process Systems Engineering (PSE) and Process Integration (PI) as well to expand students' academic horizons (Lucas et al., 2019). Since the growing awareness of the ecological footprint and environmental impact of industrial processes is currently increasing, shifts in the sphere of professional skills toolbox of chemical engineers occur. Concepts of Process Systems Engineering (PSE) and Process Integration (PI) (Azmi et al., 2017) are urgently required to be integrated into educational programs to ensure that engineers will apply appropriate environmentally-friendly methodologies for designing industrial processes.

1.2 Program learning outcomes

From the point of long-term prospective learning, outcomes are essentially linked to the core competencies that a learner should develop and possess in the course of study. In this regard, the program is to be customized based on the potential customer needs (industrial partners) and the state requirements for an educational program in Chemical Engineering. For this purpose, CBI (content-based approach) has to be utilized (Hsu and Li, 2015; Gravina, 2017; Bensah et al., 2011), as it has strong connections to project-based instruction (Stoller, 2008), critical thinking development and integrated holistic approach based on which the development of skills occurs in a multifaceted way (cross-disciplinary) with the focus on a professional subject matter.

Thus, having successfully completed this program, attendees will demonstrate:

- the fundamental knowledge in chemical engineering by summarizing every complex system through a sequence of simpler operations, explaining the advantages or downsides of any process or chemical plant processing raw hydrocarbons;
- self-learning and technical-scientific skills in the most innovative and cutting-edge areas of Chemical Engineering;
- English language command sufficient for academic and professional communication in an international setting; fluent exchange of professionally relevant information with colleagues and partners; and pursuit of professional training in English.

To assess the level of background knowledge of the staff, a range of preliminary tests has been developed. The training needs assessments (organizational, task & individual) are primarily aimed at identifying gaps in current training initiatives and employee skill sets. Moreover, the entry tests evaluate engineering activities, hard skills, soft skills, and the command of English. The type of test tasks comprises the calculation of the basic engineering indicators, checking the knowledge of industrial chemistry, polymer chemistry, the patent system, economics, and the elements of chemical engineering modeling. Afterward, these gaps are analyzed, prioritized, and turned into the organization's training objectives.

1.3 Curricular structure

Thus, the educational curriculum is designed to be flexible and the preapproved structure for the joint program curriculum includes the next main stages:

1. Entry testing procedures for industry fellows, team building (around 15 members), and project topics assignment.
2. All modules delivered by Tomsk Polytechnic University, for instance, Foundations of Chemical Engineering, Simulation of Chemical Processes and Applied Kinetics, Industrial Catalysis, Polymer Chemistry (Advanced Level), Polyolefins Production, and others are developed particularly for the aims of the industrial partners. Generally, these modules are taught in Russian (the native language of participants) together with the integration of the specially designed module – English for Engineering.

3. Modules delivered by Politecnico di Milano, such as Chemical Plants/ Process Plants, Dynamics and Control of Chemical Processes are focused on maintaining for engineering project solution.
4. Finally, the attendees perform the deliverables of their project's solutions.

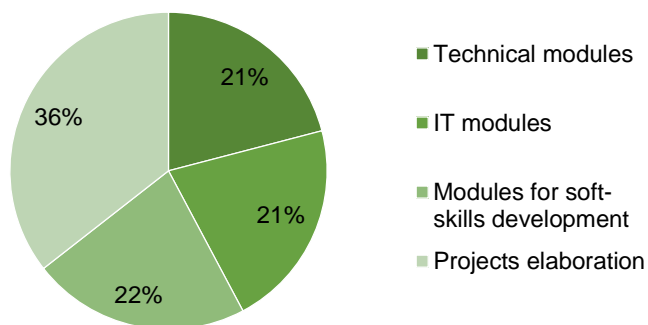

Fig.2: Distribution of credit hours

The content of the designing program is intended to strengthen cross-training between background knowledge and technical applicative skills and is based on the interdisciplinary and cooperative collaboration of Tomsk Polytechnic University and Politecnico di Milano. Thus, the total amount of academic credits was 1710 hours and it is equally distributed among the four blocks (see Fig. 2). The credit hours allocated and distributed in compliance with the program meet the requirements and main guidelines of system engineering (ISO/IEC 15288:2008(E), IEEE Std 15288, 2008).

Because of the current situation around the world and new challenges emerged, the major part of the training program content has been delivered distantly.

2. Project Work Overview

The key feature of the program under consideration is the use of a project-based approach as is one of the learning methodologies more effective in the widening of Chemical Engineer competencies (Helle et al., 2006). In this regard, the curriculum is based around term projects where the topics of investigation are suggested and selected by the participants in correlation with their professional duties. Specifically, attendees rigorously elaborate engineering cases (in groups of 2-3 or individually) that are crucial for SIBUR. This project work includes a scientific overview of the project topic, process optimization issues (which provide an output of high-quality chemical products), and the development of a strategy for processes of petrochemical production. During the study, the following methods for problem-solving have been utilized: determination of optimal parameters of chemical processes, flow diagrams, computer modeling, data analysis, and experimental data handling.

The basic block of the program is aimed at the development of IT skills, for this purpose, it is comprised of practice and real-life-oriented activities to improve simulation software skills such as Pro/II, DynSim, Unisim, and Aspen HYSIS. As a result, each attendee is capable of designing a model (an example is shown in Fig.3) which simulates a real industrial unit.

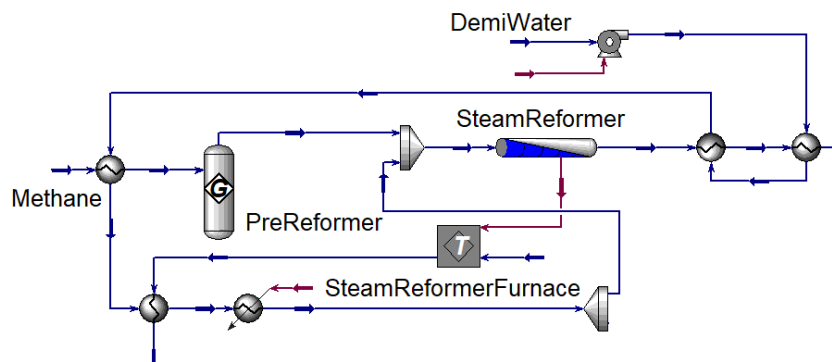

Fig.3: Example of modeling for a project solution. Here it is shown the steam reforming – a method for producing syngas (hydrogen and carbon monoxide) by reaction of hydrocarbons with water.

During the project presentation session, the learners demonstrate the result of the work done in compliance with the assessment criteria set, among which the project structure is as follows:

- Project Title / Team / Outline / Project Relevance;
- Problem and Solution Identification;
- Design Solution;
- Economic Impact Analysis;
- Risk Mitigation;
- References / Supplementary Materials.

Each stage of the project is accompanied by project guide supervision and conducted with the help of a close collaboration between the experts in the field, a teaching staff, and the students. Thus, the current undertaking involves a team comprised of different domain experts from various tertiary institutions. Moreover, the critical reviews from Sibur's experts are considered as the general assessment tool for this program.

To sum up, the deliverables of the performed projects were estimated at a high level by SIBUR experts. It gives opportunities for later implementation of the 2025 Sustainability Strategy and the principles of a circular economy.

3. Conclusions

Graduate trainees of this joint program receive enough competencies to meet the needs of the industrial sector (PJSC SIBUR Holding), innovation and development of production, advanced design of both traditional and innovative chemical processes, planning and programming, and management of complex systems. The proposed scheme of education allowed balancing the competence realization, acquisition of international experience, and achieving the deliverables for engineering cases solutions. Additionally, the project comprised issues on project constraints, general accomplishments, financial analysis, and the marginality of the project solutions implementation. During the program implementation period, the following inferences and recommendations can be made: to reconsider the entry test content and requirements (to make them more customized), to raise the requirements towards command of English. It was also offered to indicate a two-level system of training aimed at selection of the best learners (based on the results of the final task and achievement test completion) who will pursue the second level the focus of which is to introduce a module on computer modeling of specific processes and digital training in Chemical Engineering.

Acknowledgments

The authors acknowledge and thank the PJSC SIBUR Holding, as without financial contributions from the industrial partners no program would have been possible.

References

- Aviso K.B., Lucas R.I.G., Tapia J.F.D., Promentilla M.A.B., Tan R.R., 2018, Identifying key factors to learning process systems engineering and process integration through DEMATEL, *Chemical Engineering Transactions*, 70, 265-270.
- Azmi N.A., Yusof K.M., Phang F.A., 2017, How to motivate chemical engineering undergraduates to learn programming? *Chemical Engineering Transactions*, 56, 1303-1308.
- Bensah E.C., Ahiekpor J.C., Boateng C.D., 2011, Migrating from subject-based to competency-based training in Higher National Diploma Chemical Engineering: The case of Kumasi Polytechnic, *Education for Chemical Engineers*, 6, e71-e82.
- Cesaroni F., Gambardella A., Garcia-Fontes W., 2004, *R&D, Innovation and Competitiveness In The European Chemical Industry*, Kluwer Academic Publishers, Netherlands.
- Focus on what really matters, Annual review, Sibur, 2019, RF, <sibur.ru/en/> accessed 01.12.2020.
- Gravina E.W., 2017, Competency-Based Education and its effect on Nursing Education: A literature review, *Teaching and Learning in Nursing*, 12, 117-121.
- Helle L., Tynjala P., & Olkinuora E. 2006. Project-based learning in post-secondary education – theory, practice and rubber sling shots. *Higher Education*, 51(2), 287-314.
- Hsu W.C., Li C.H., 2015, A competency-based guided-learning algorithm applied on adaptively guiding elearning, *Interactive Learning Environments*, 23, 106 –125.
- Lucas R.I.G., Aviso K.B., Promentilla M. A. B., Čuček L., Isafiade A. J., Lee J.-Y., Tan R.R., 2019, Comparing Learning Strategies in Understanding Process Integration, Optimization and Sustainability, *Chemical Engineering Transactions*, 76, 835-840.
- Rozanova Y. V., Sidorenko T.V., Shamina O.B., 2020, English for Specific Purposes Instruction and Research, Chapter 15, *CLIL: A Public Technical University Experience*, 289 – 305.

Rutmann T., 2019, Engineering Pedagogy as the Basis for Effective Teaching Competencies of Engineering Faculty, *Vyssshee obrazovanie v Rossii = Higher Education in Russia*. Vol. 28, (12), 123 – 131.

Stoller, F. (2008). *Content-based instruction: Second and foreign language education*. New York: Springer, Chapter 10, *Project Work: A Means to Promote Language and Content*, 107 – 120.

Yankwich P. E., 1984, *Industrial-Academic Cooperation in Education*, Chapter 8, 51 – 58.

ISO/IEC 15288:2008(E), IEEE Std 15288, 2008, *Systems and software engineering – System life cycle processes* <iso.org/obp/ui/#iso:std:iso-iec:15288:ed-2:v1:en> accessed 10.12.2020.